

# INSTALLATION MANUAL

## RESIDENTIAL GAS FURNACE MODELS

TM9X\*MP – High Efficiency Motor

(95.5% AFUE Single Stage Multi-position)



### LIST OF SECTIONS

SAFETY .....	1	COMBUSTION AIR and VENT SYSTEM .....	20
DUCTWORK .....	4	START-UP AND ADJUSTMENTS .....	27
FILTERS .....	8	SAFETY CONTROLS .....	30
GAS PIPING .....	9	REPLACEMENT PARTS LIST .....	33
ELECTRICAL POWER .....	10	REPLACEMENT PART CONTACT INFORMATION .....	33
CONDENSATE PIPING AND FURNACE VENTING CONFIGURATION .....	14	WIRING DIAGRAM .....	34

### LIST OF FIGURES

Duct Attachment .....	5	Upflow Configuration .....	16
Vertical Applications .....	5	Downflow Configuration .....	17
Coil Flange .....	6	Horizontal Left Configuration .....	18
Horizontal Right Application .....	6	Horizontal Right Configuration .....	19
Horizontal Left Application .....	6	Dimensions .....	20
PC Series Upflow Coil Installation .....	6	Home Layout .....	22
Horizontal Left or Right application (Right Shown) .....	6	Termination Configuration - 1 Pipe .....	23
Combustible Floor Base Accessory .....	7	Termination Configuration - 2 Pipe .....	23
Horizontal Application .....	7	Termination Configuration - 2 Pipe Basement .....	23
Typical Attic Installation .....	7	Double Horizontal Combustion Air Intake and Vent Termination .....	23
Typical Suspended Furnace / Crawl Space Installation .....	7	Double Vertical Combustion Air Intake and Vent Termination .....	23
Dimensions .....	8	Direct Vent Air Intake Connection and Vent Connection .....	24
Side Return Cutout Markings .....	9	Combustion Airflow Path Through The Furnace Casing .....	24
Gas Valve .....	9	Outside and Ambient Combustion Air .....	25
Upflow/Downflow Gas Piping .....	9	Attic and Crawl Space Combustion Air Termination .....	26
Horizontal Gas Piping .....	9	Gas Valve .....	29
Electrical Wiring .....	11	Reading Gas Pressure .....	29
Thermostat Chart - Single Stage AC with Single Stage Furnaces .....	12	Furnace Control Board .....	30
Thermostat Chart - Single Stage HP with Single Stage Furnaces .....	13	Furnace Control Event Schedule .....	32
Typical. Condensate drain, vertical installation. ....	14	Wiring Diagram .....	34
Typical. Combustion Pipe Drain Tee. ....	15		

### LIST OF TABLES

Unit Clearances to Combustibles .....	4	Combustion Air Intake and Vent Connection Size at Furnace (All Models) .....	21
Coil Projection Dimensions - PC Series Coils .....	6	Estimated Free Area .....	24
Cabinet and Duct Dimensions .....	8	Unconfined Space Minimum Area in Square Inch .....	25
Recommended Filter Sizes (High Velocity 600 FPM) .....	8	Free Area .....	25
Nominal Manifold Pressure - High Fire .....	10	Gas Rate (CU FT/HR) at Full Input .....	28
Ratings & Physical / Electrical Data .....	11	Inlet Gas Pressure Range .....	29
Maximum Equivalent Pipe Length .....	20	Nominal Manifold Pressure .....	29
Elbow Dimensions .....	20		
Equivalent Length of Fittings .....	21		

These high efficiency, compact units employ induced combustion, reliable hot surface ignition and high heat transfer aluminized tubular heat exchangers. The units are factory shipped for installation in upflow or horizontal applications and may be converted for downflow applications.

These furnaces are designed for residential installation in a basement, closet, alcove, attic, recreation room or garage and are also ideal for commercial applications. All units are factory assembled, wired and tested to assure safe dependable and economical installation and operation.

These units are Category IV listed and may not be common vented with another gas appliance as allowed by the National Fuel Gas Code.

## SECTION I: SAFETY



This is a safety alert symbol. When you see this symbol on labels or in manuals, be alert to the potential for personal injury.

Understand and pay particular attention to the signal words **DANGER**, **WARNING**, or **CAUTION**.

**DANGER** indicates an **imminently** hazardous situation, which, if not avoided, **will result in death or serious injury**.

**WARNING** indicates a **potentially** hazardous situation, which, if not avoided, **could result in death or serious injury**.

**CAUTION** indicates a potentially hazardous situation, which, if not avoided **may result in minor or moderate injury**. It is also used to alert against unsafe practices and hazards involving only property damage.

### WARNING

*Improper installation may create a condition where the operation of the product could cause personal injury or property damage.*

*Improper installation, adjustment, alteration, service or maintenance can cause injury or property damage. **Failure to carefully read and follow all instructions in this manual can result in furnace malfunction, death, personal injury and/or property damage.** Only a qualified contractor, installer or service agency should install this product.*

## SPECIFIC SAFETY RULES AND PRECAUTIONS

1. Only Natural gas or Propane (LP) gas are approved for use with this furnace.
2. Install this furnace only in a location and position as specified in these instructions.
3. A gas-fired furnace for installation in a residential garage must be installed as specified in these instructions.
4. Provide adequate combustion and ventilation air to the furnace space as specified in these instructions.
5. Combustion products must be discharged outdoors. Connect this furnace to an approved vent system only, as specified in SECTION VII, "COMBUSTION AIR and VENT SYSTEM" of these instructions.
6. Test for gas leaks as specified in these instructions.

### **WARNING**

#### **FIRE OR EXPLOSION HAZARD**

*Failure to follow the safety warnings exactly could result in serious injury, death or property damage.*

*Never test for gas leaks with an open flame. Use a commercially available soap solution made specifically for detection of leaks to check all connections. A fire or explosion may result causing property damage, personal injury or loss of life.*

7. Always install the furnace to operate within the furnace's intended temperature rise range. Only connect the furnace to a duct system which has an external static pressure within the allowable range, as specified on the furnace rating plate.
8. When a furnace is installed so that supply ducts carry air circulated by the furnace to areas outside the space containing the furnace, the return air shall also be handled by duct(s) sealed to the furnace casing and terminating outside the space containing the furnace.
9. It is permitted to use the furnace for heating of buildings or structures under construction where the application and use must comply with all manufacturer's installation instructions including:
  - Proper vent installation;
  - Furnace operating under thermostatic control;
  - Return air duct sealed to the furnace;
  - Air filters in place;
  - Set furnace input rate and temperature rise per rating plate marking;
  - Means for providing outdoor air required for combustion;
  - Return air temperature maintained between 55°F (13°C) and 80°F (27°C);
  - The **air filter must be replaced** upon substantial completion of the construction process;
  - Clean furnace, duct work and components upon substantial completion of the construction process, and verify furnace-operating conditions including ignition, input rate, temperature rise and venting, according to the manufacturer's instructions.
10. When installed in a non-HUD-Approved Modular Home or building constructed on-site, combustion air shall not be supplied from occupied spaces.
11. The size of the unit should be based on an acceptable heat loss calculation for the structure. ACCA, Manual J or other approved methods may be used.

## SAFETY REQUIREMENTS

### **CAUTION**

*This product must be installed in strict compliance with the installation instructions and any applicable local, state, and national codes including, but not limited to building, electrical, and mechanical codes.*

- Refer to the unit rating plate for the furnace model number, and then see the dimensions page of this instruction for return air plenum dimensions in Figure 12. The plenum must be installed according to the instructions.
- Provide clearances from combustible materials as listed under Clearances to Combustibles.
- Provide clearances for servicing ensuring that service access is allowed for both the burners and blower.
- These models **ARE NOT** CSA listed or approved for installation into a **HUD Approved Modular Home** or a **Manufactured (Mobile) Home**.
- This furnace is not approved for installation in trailers or recreational vehicles.
- Furnaces for installation on combustible flooring shall not be installed directly on carpeting, tile or other combustible material other than wood flooring.
- Check the rating plate and power supply to be sure that the electrical characteristics match. All models use nominal 115 VAC, 1 Phase, 60-Hz power supply. **DO NOT CONNECT THIS APPLIANCE TO A 50-Hz POWER SUPPLY OR A VOLTAGE ABOVE 130 VOLTS.**
- Furnace shall be installed so the electrical components are protected from water.
- Installing and servicing heating equipment can be hazardous due to the electrical components and the gas fired components. Only trained and qualified personnel should install, repair, or service gas heating equipment. Untrained service personnel can perform basic maintenance functions such as cleaning and replacing the air filters. When working on heating equipment, observe precautions in the manuals and on the labels attached to the unit and other safety precautions that may apply.

## COMBUSTION AIR QUALITY (LIST OF CONTAMINANTS)

The furnace requires **OUTDOOR AIR** for combustion when the furnace is located in any of the following environments.

- Buildings with indoor pools
- Chemical exposure
- Commercial buildings
- Furnaces installed in hobby or craft rooms
- Furnaces installed in laundry rooms
- Furnaces installed near chemical storage areas
- Restricted Environments

The furnace requires **OUTDOOR AIR** for combustion when the furnace is located in an area where the furnace is being exposed to the following substances and / or chemicals.

- Antistatic fabric softeners for clothes dryers
- Carbon tetrachloride
- Cements and glues
- Chlorinated waxes and cleaners
- Chlorine based swimming pool chemicals
- Cleaning solvents (such as perchloroethylene)
- De-icing salts or chemicals
- Halogen type refrigerants
- Hydrochloric acid
- Masonry acid washing materials
- Permanent wave solutions
- Printing inks, paint removers, varnishes, etc.
- Water softening chemicals

When outdoor air is used for combustion, the combustion air intake duct system termination must be located external to the building and in an area where there will be no exposure to the substances listed above.

**WARNING**

*The furnace area must not be used as a broom closet or for any other storage purposes, as a fire hazard may be created. Never store items such as the following on, near or in contact with the furnace.*

1. Spray or aerosol cans, rags, brooms, dust mops, vacuum cleaners or other cleaning tools.
2. Soap powders, bleaches, waxes or other cleaning compounds; plastic items or containers; gasoline, kerosene, cigarette lighter fluid, dry cleaning fluids or other volatile fluid.
3. Paint thinners and other painting compounds.
4. Paper bags, boxes or other paper products

**Never operate the furnace with the blower door removed. To do so could result in serious personal injury and/or equipment damage.**

## CODES AND STANDARDS

Follow all national, local codes and standards in addition to this installation manual. The installation must comply with regulations of the serving gas supplier, local building, heating, plumbing, and other codes. In absence of local codes, the installation must comply with the national codes listed below and all authorities having jurisdiction.

In the United States and Canada, follow all codes and standards for the following, using the latest edition available:

### STEP 1 -Safety

- US: National Fuel Gas Code (NFGC) NFPA 54/ANSI Z223.1 and the Installation Standards, Warm Air Heating and Air Conditioning Systems ANSI/NFPA 90B
- CANADA: CAN/CGA-B149.1 National Standard of Canada. Natural Gas and Propane Installation Codes (NSCNGPIC)

### STEP 2 -General Installation

- US: Current edition of the NFGC and NFPA 90B. For copies, contact the  
National Fire Protection Association Inc.  
Batterymarch Park  
Quincy, MA 02269  
or for only the NFGC, contact the  
American Gas Association,  
400 N. Capital, N.W.  
Washington DC 20001  
or www.NFPA.org
- CANADA: NSCNGPIC. For a copy contact:  
Standard Sales, CSA International  
178 Rexdale Boulevard  
Etobicoke, (Toronto) Ontario Canada M9W 1R5

### STEP 3 -Combustion and Ventilation Air

- US: Section 5.3 of the NFGC, air for Combustion and Ventilation
- CANADA: Part 7 of NSCNGPIC, Venting Systems and Air Supply for Appliances

### STEP 4 -Duct Systems

- US and CANADA: Air Conditioning Contractors Association (ACCA) Manual D, Sheet Metal and Air Conditioning Contractors Association National Association (SMACNA), or American Society of Heating, Refrigeration, and Air Conditioning Engineers (ASHRAE) 1997 Fundamentals Handbook Chapter 32.

### STEP 5 -Acoustical Lining and Fibrous Glass Duct

- US and CANADA: Current edition of SMACNA and NFPA 90B as tested by UL Standard 181 for Class I Rigid Air Ducts

### STEP 6 -Gas Piping and Gas Pipe Pressure Testing

- US: NFGC; chapters 2, 3, 4, & 9 and National Plumbing Codes
- CANADA: NSCNGPIC Part 5

### STEP 7 -Electrical Connections

- US: National Electrical Code (NEC) ANSI/NFPA 70
- CANADA: Canadian Electrical Code CSA C22.1

These instructions cover minimum requirements and conform to existing national standards and safety codes. In some instances these instructions exceed certain local codes and ordinances, especially those who have not kept up with changing residential and non-HUD modular home construction practices. These instructions are required as a minimum for a safe installation.

## FOR FURNACES INSTALLED IN THE COMMONWEALTH OF MASSACHUSETTS ONLY

For all side wall horizontally vented gas fueled equipment installed in every dwelling, building or structure used in whole or in part for residential purposes, including those owned or operated by the Commonwealth and where the side wall exhaust vent termination is less than seven (7) feet above finished grade in the area of the venting, including but not limited to decks and porches, the following requirements shall be satisfied:

1. **INSTALLATION OF CARBON MONOXIDE DETECTORS.** At the time of installation of the side wall horizontal vented gas fueled equipment, the installing plumber or gasfitter shall observe that a hard wired carbon monoxide detector with an alarm and battery back-up is installed on the floor level where the gas equipment is to be installed. In addition, the installing plumber or gasfitter shall observe that a battery operated or hard wired carbon monoxide detector with an alarm is installed on each additional level of the dwelling, building or structure served by the side wall horizontal vented gas fueled equipment. It shall be the responsibility of the property owner to secure the services of qualified licensed professionals for the installation of hard wired carbon monoxide detectors
  - a. In the event that the side wall horizontally vented gas fueled equipment is installed in a crawl space or an attic, the hard wired carbon monoxide detector with alarm and battery back-up may be installed on the next adjacent floor level.
  - b. In the event that the requirements of this subdivision can not be met at the time of completion of installation, the owner shall have a period of thirty (30) days to comply with the above requirements; provided, however, that during said thirty (30) day period, a battery operated carbon monoxide detector with an alarm shall be installed.
2. **APPROVED CARBON MONOXIDE DETECTORS.** Each carbon monoxide detector as required in accordance with the above provisions shall comply with NFPA 720 and be ANSI/UL 2034 listed and IAS certified.
3. **SIGNAGE.** A metal or plastic identification plate shall be permanently mounted to the exterior of the building at a minimum height of eight (8) feet above grade directly in line with the exhaust vent terminal for the horizontally vented gas fueled heating appliance or equipment. The sign shall read, in print size no less than one-half (1/2) inch in size, "**GAS VENT DIRECTLY BELOW. KEEP CLEAR OF ALL OBSTRUCTIONS**".
4. **INSPECTION.** The state or local gas inspector of the side wall horizontally vented gas fueled equipment shall not approve the installation unless, upon inspection, the inspector observes carbon monoxide detectors and signage installed in accordance with the provisions of 248 CMR 5.08(2)(a)1 through 4.

## INSPECTION

As soon as a unit is received, it should be inspected for possible damage during transit. If damage is evident, the extent of the damage should be noted on the carrier's freight bill. A separate request for inspection by the carrier's agent should be made in writing. Also, before installation, the unit should be checked for screws or bolts which may have loosened in transit. There are no shipping or spacer brackets which need to be removed from the interior of this unit.

## FURNACE LOCATION AND CLEARANCES

### The furnace shall be located using the following guidelines:

1. Where a minimum amount of air intake/vent piping and elbows will be required.
2. As centralized with the air distribution as possible.
3. Where adequate combustion air will be available (particularly when the appliance is not using outdoor combustion air).
4. Where it will not interfere with proper air circulation in the confined space.
5. Where the outdoor vent terminal will not be blocked or restricted. Refer to "VENT CLEARANCES" located in SECTION VII of these instructions. These minimum clearances must be maintained in the installation.
6. Where the unit will be installed in a level position with no more than 1/4" (6.4 mm) slope side-to-side and front-to-back to provide proper condensate drainage.

### Installation in freezing temperatures:

1. Furnace shall be installed in an area where ventilation facilities provide for safe limits of ambient temperature under normal operating conditions. Ambient temperatures must not fall below 32°F (0°C) unless the condensate system is protected from freezing.

### WARNING

*Improper installation in an ambient below 32°F (0°C) could create a hazard, resulting in damage, injury or death.*

2. Do not allow return air temperature to be below 55°F (13°C) for extended periods. To do so may cause condensation to occur in the main heat exchanger, leading to premature heat exchanger failure.
3. If this furnace is installed in an unconditioned space and an extended power failure occurs, there will be potential damage to the internal components. Following a power failure situation, do not operate the unit until inspection and repairs are performed.
4. Special precautions MUST be made if installing furnace in an area which may drop below freezing. This can cause improper operation or damage to the equipment. If the furnace is installed in an area that has the potential of freezing, the drain line must be protected. Use a 3 to 6 watt per foot at 115 vac, 40°F (4.4°C) self-regulating, shielded and waterproof heat tape. Wrap the drain line outside of the furnace with the heat tape and secure with ties. Follow the heat tape manufacturer's recommendations.

### WARNING

*We have conducted limited freeze tests with the new condensate pans and have not witnessed any issues. No anti-freeze is approved at this time to be used in the new condensate pans.*

### Clearances for access/service:

Ample clearances should be provided to permit easy access to the unit. The following minimum clearances are recommended:

1. Twenty-four (24) inches (61 cm) between the front of the furnace and an adjacent wall or another appliance, when access is required for servicing and cleaning.
2. Eighteen (18) inches (46 cm) at the side where access is required for passage to the front when servicing or for inspection or replacement of flue/vent connections.

In all cases, accessibility clearances shall take precedence over clearances for combustible materials where accessibility clearances are greater.

### Installation in a residential garage:

A gas-fired furnace for installation in a residential garage must be installed so the burner(s) and the ignition source are located not less than 18" (46 cm) above the floor, and the furnace must be located or protected to avoid physical damage by vehicles.

**Table 1: Unit Clearances to Combustibles**

Application	Upflow	Downflow	Horizontal
Top	1"	0"	0"
Vent	0"	0"	0"
Rear	0"	0"	0"
Side	0"	0"	1"
Front*	0"	0"	0"
Floor	Combustible	Combustible <sup>1</sup>	Combustible
Closet	Yes	Yes	Yes
Line Contact	No	No	Yes

1. For combustible floors only when used with special sub-base.

\* 24" clearance in front and 18" on side recommended for service access. All furnaces approved for alcove and attic installation.

## SECTION II: DUCTWORK

### DUCTWORK GENERAL INFORMATION

#### The duct system's design and installation must:

1. Handle an air volume appropriate for the served space and within the operating parameters of the furnace specifications.
2. Be installed in accordance of National Fire Protection Association as outlined in NFPA standard 90B (latest editions) or applicable national, provincial, state, and local fire and safety codes.
3. Create a closed duct system. For residential and non-HUD Modular Home installations, when a furnace is installed so that the supply ducts carry air circulated by the furnace to areas outside the space containing the furnace, the return air shall also be handled by a duct(s) sealed to the furnace casing and terminating outside the space containing the furnace.
4. Complete a path for heated or cooled air to circulate through the air conditioning and heating equipment and to and from the conditioned space.

### CAUTION

*The cooling coil must be installed in the supply air duct, downstream of the furnace. Cooled air may not be passed over the heat exchanger.*

When the furnace is used with a cooling coil, the coil must be installed parallel with, or in the supply air side of the furnace to avoid condensation in the primary heat exchanger. When a parallel flow arrangement is used, dampers or other means used to control airflow must be adequate to prevent chilled air from entering the furnace. If manually operated, the damper must be equipped with means to prevent the furnace or the air conditioner from operating unless the damper is in full heat or cool position.

When replacing an existing furnace, if the existing plenum is not the same size as the new furnace then the existing plenum must be removed and a new plenum installed that is the proper size for the new furnace. If the plenum is shorter than 12" (30.5 cm) the turbulent air flow may cause the limit controls not to operate as designed, or the limit controls may not operate at all.

The duct system is a very important part of the installation. **If the duct system is improperly sized the furnace will not operate properly.** The ducts attached to the furnace plenum, should be of sufficient size so that the furnace operates at the specified external static pressure and within the air temperature rise specified on the nameplate.

### IMPORTANT

*The minimum plenum height is 12" (30.5 cm). The furnace will not operate properly on a shorter plenum height. The minimum recommended rectangular duct height is 4" (10.1 cm) attached to the plenum.*

If a matching cooling coil is used, it may be placed directly on the furnace outlet and sealed to prevent leakage. If thermoplastic evaporator 'A' coil drain pans are to be installed in the upflow/horizontal configuration, then extra 2" minimum spacing may be needed to ensure against drain pan distortion.

On all installations without a coil, a removable access panel is recommended in the outlet duct such that smoke or reflected light would be observable inside the casing to indicate the presence of leaks in the heat exchanger. This access cover shall be attached in such a manner as to prevent leaks.

## WARNING

The duct system must be properly sized to obtain the correct airflow for the furnace size that is being installed.

Refer to Table 6 or the furnace rating plate for the correct rise range and static pressures.

If the ducts are undersized, the result will be high duct static pressures and/or high temperature rises which can result in a heat exchanger OVERHEATING CONDITION. This condition can result in premature heat exchanger failure, which can result in personal injury, property damage, or death.

## DUCT FLANGES

Four flanges are provided to attach ductwork to the furnace. These flanges are rotated down for shipment. In order to use the flanges, remove the screw holding an individual flange, rotate the flange so it is in the upward position and reinstall the screw then repeat this for all 4 flanges.

If the flanges are not used, they must remain in the rotated down position as shipped.

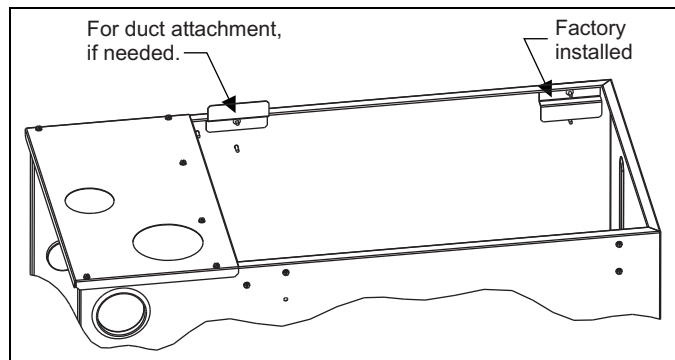

FIGURE 1: Duct Attachment

## DUCTWORK INSTALLATION AND SUPPLY PLENUM CONNECTION - UPFLOW/HORIZONTAL



Attach the supply plenum to the furnace outlet. The use of an approved flexible duct connector is recommended on all installations. This connection should be sealed to prevent air leakage. The sheet metal should be crosshatched to eliminate any popping of the sheet metal when the indoor fan is energized.

## FLOOR BASE AND DUCTWORK INSTALLATION - DOWNFLOW

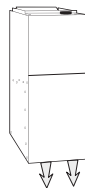

Installations on combustible material or directly on any floors must use a combustible floor base shown in Figure 8. Follow the instructions supplied with the combustible floor base accessory. This combustible floor base can be replaced with a matching cooling coil, properly sealed to prevent leaks. Follow the instructions supplied with the cooling coil cabinet for installing the cabinet to the duct connector. Plug intake and vent pipe holes in bottom panel and move grommet to desired vent side exit.

## Downflow Air Conditioning Coil Cabinet

The furnace should be installed with coil cabinet part number specifically intended for downflow application. If a matching cooling coil is used, it may be placed directly on the furnace outlet and sealed to prevent leakage. For details of the coil cabinet dimensions and installation requirements, refer to the installation instructions supplied with the coil cabinet.

Attach the air conditioning coil cabinet to the duct connector, and then position the furnace on top of the coil cabinet. The connection to the furnace, air conditioning coil cabinet, duct connector, and supply air duct must be sealed to prevent air leakage.

## COIL INSTALLATION

## IMPORTANT

On all installations without a coil, a removable access panel is recommended in the outlet duct such that smoke or reflected light would be observable inside the casing to indicate the presence of leaks in the heat exchanger. This access cover shall be attached in such a manner as to prevent leaks.

## COIL/FURNACE ASSEMBLY - MC/FC/PC SERIES COILS

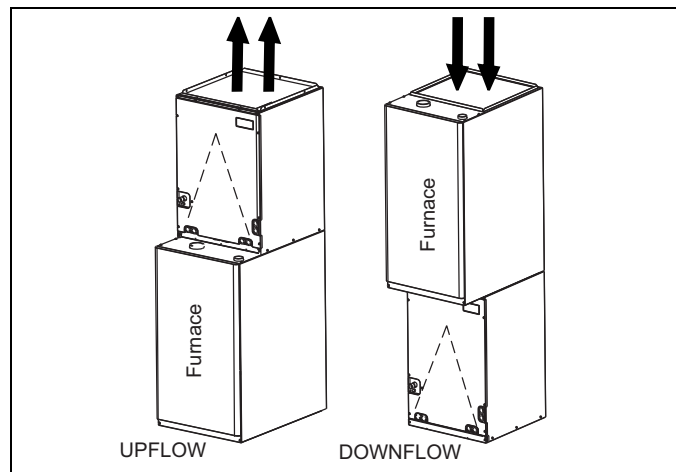

FIGURE 2: Vertical Applications

## FURNACE ASSEMBLY - MC & FC SERIES COILS

These coils are factory shipped for installation in either upflow or downflow applications with no conversion.

Position the coil casing over or under the furnace opening as shown in Figure 2 after configuring coil flanges as required see "Coil Flange" section below.

### COIL FLANGE INSTALLATION

The coils include removable flanges to allow proper fit up with furnaces having various inlet and outlet flange configurations. The two flanges are attached to the top of the coil in the factory during production. For proper configuration of flanges refer to Figure 3.

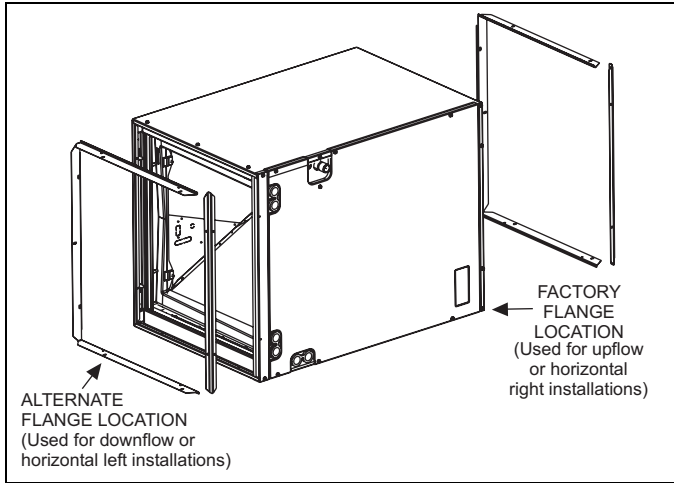

FIGURE 3: Coil Flange

### FURNACE ASSEMBLY - MC SERIES COILS ONLY

MC coils are supplied ready to be installed in a horizontal position. A horizontal pan is factory installed. MC coils should be installed in all horizontal applications with the horizontal drain pan side down.

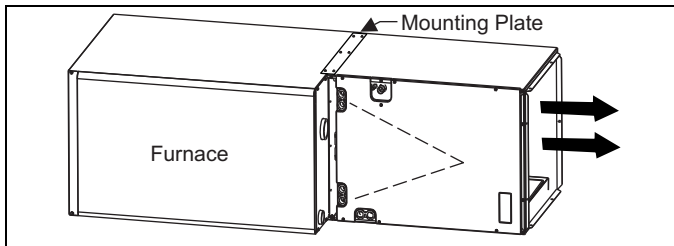

FIGURE 4: Horizontal Right Application

For horizontal left hand applications no conversion is required to an MC coil when used with a downflow/horizontal furnace. A mounting plate, supplied with every coil should always be installed on the side designated as top side. See Figure 4 & 5.

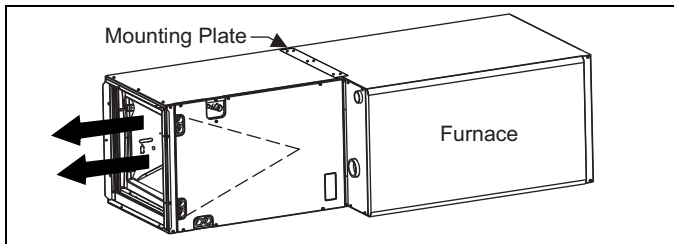

FIGURE 5: Horizontal Left Application

### FURNACE ASSEMBLY - PC SERIES COILS

These upflow coils are designed for installation on top of upflow furnaces only.

If the coil is used with a furnace of a different size, use a 45° transition to allow proper air distribution through the coil.

1. Position the coil casing over the furnace opening as shown in Figure 6.
2. Place the ductwork over the coil casing flange and secure.
3. Check for air leakage between the furnace and coil casing and seal appropriately.

## ⚠ CAUTION

Do not drill any holes or drive any screws into the front duct flange on the coil in order to prevent damaging coil tubing. See Figure 6.

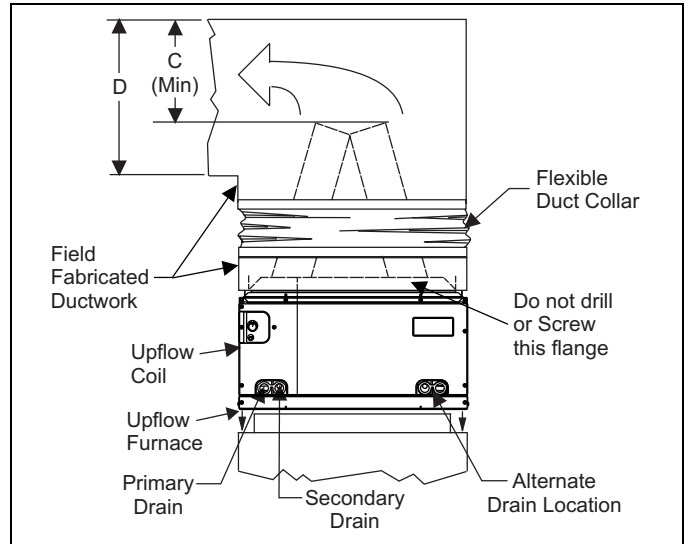

FIGURE 6: PC Series Upflow Coil Installation

Table 2: Coil Projection Dimensions - PC Series Coils

COIL SIZE	DIMENSION "C" INCH
PC18	3-1/2
PC24	4-1/2
PC30, PC32, PC35	4-1/2
PC42, PC43, PC36, PC37	5-1/2
PC48	6-1/2
PC60	9

**NOTE:** Dimension "C" should be at least 2/3 of dimension "D". See Figure 6.

### CRITICAL COIL PROJECTION

The coil assembly must be located in the duct such that a minimum distance is maintained between the top of the coil and the top of the duct. Refer to Table 2.

### COIL / FURNACE ASSEMBLY - HC SERIES COILS

These coils are supplied ready to be installed in a right hand position or a left hand position. When used in conjunction with a horizontal furnace (blow through) application, the coil should be oriented with the opening of the "A" coil closest to the furnace. See Figure 7.

**NOTE:** Each coil is shipped with an external tie plate that should be used to secure the coil to the furnace. It should be installed on the back side of the coil using the dimpled pilot holes. See Figure 7.

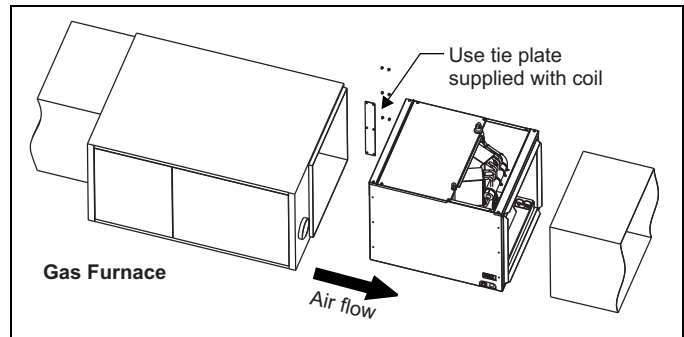

FIGURE 7: Horizontal Left or Right application (Right Shown)

## DOWNFLOW DUCT CONNECTORS

All downflow installations must use a suitable duct connector approved by the furnace manufacturer for use with this furnace. The duct connectors are designed to be connected to the rectangular duct under the floor and sealed. Refer to the instructions supplied with the duct connector for proper installation. Refer to the separate accessory parts list at the end of these instructions for the approved accessory duct connectors.

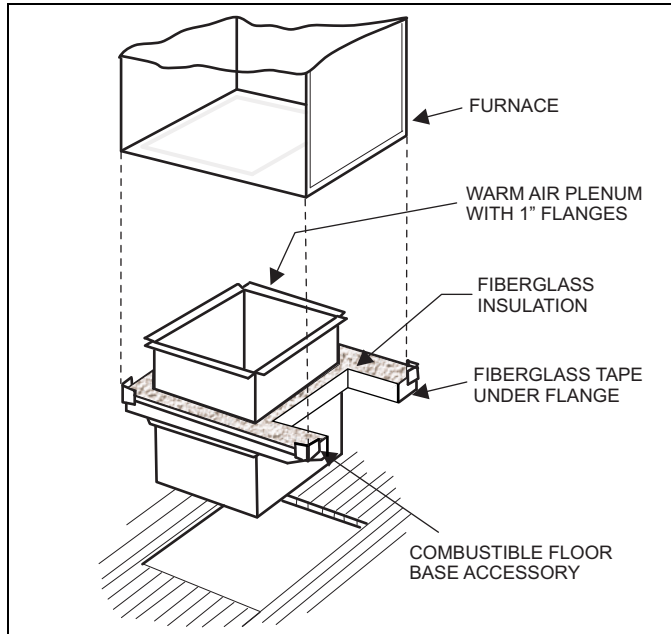

FIGURE 8: Combustible Floor Base Accessory

## RESIDENTIAL AND MODULAR HOME UPFLOW RETURN PLENUM CONNECTION

Return air may enter the furnace through the side(s) or bottom depending on the type of application. Return air may not be connected into the rear panel of the unit.

## BOTTOM RETURN AND ATTIC INSTALLATIONS

Bottom return applications normally pull return air through a base platform or return air plenum. Be sure the return platform structure or return air plenum is suitable to support the weight of the furnace.

The internal bottom panel must be removed for this application.

Attic installations must meet all minimum clearances to combustibles and have floor support with required service accessibility.

## HORIZONTAL APPLICATION

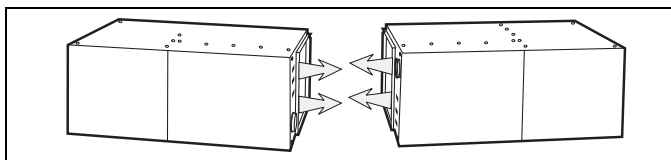

FIGURE 9: Horizontal Application

## IMPORTANT

This furnace may be installed in a horizontal position on either side as shown above. ***It must not be installed on its back.***

## ATTIC INSTALLATION

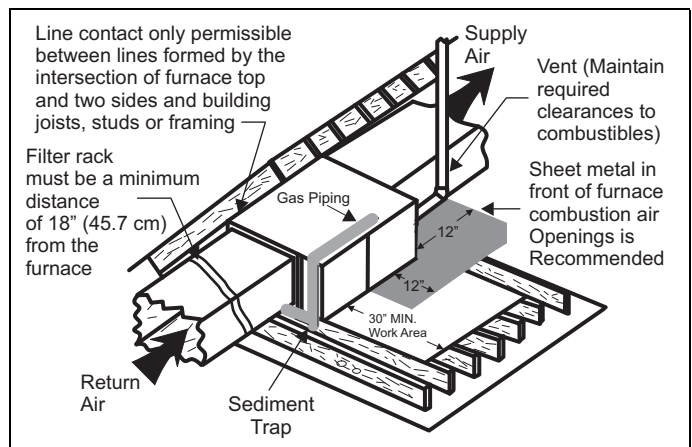

FIGURE 10: Typical Attic Installation

This appliance is certified for line contact when the furnace is installed in the horizontal left or right position. The line contact is only permissible between lines that are formed by the intersection of the top and two sides of the furnace and the building joists, studs or framing. This line may be in contact with combustible material. Refer to Figure 10.

## WARNING

*When a furnace is installed in an attic or other insulated space, keep all insulating materials at least 12" (30.5 cm) away from furnace and burner combustion air openings.*

## SUSPENDED FURNACE / CRAWL SPACE INSTALLATION

The furnace can be hung from floor joists or installed on suitable blocks or pad. Blocks or pad installations shall provide adequate height to ensure the unit will not be subject to water damage. Units may also be suspended from rafters or floor joists using rods, pipe angle supports or straps. Angle supports should be placed at the supply air end and near the blower deck. Do not support at return air end of unit. All four suspension points must be level to ensure quite furnace operation. When suspending the furnace use a secure platform constructed of plywood or other building material secured to the floor joists. Refer to for typical crawl space installation.

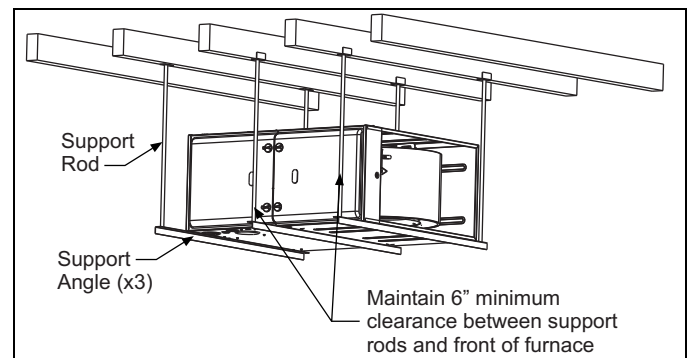

FIGURE 11: Typical Suspended Furnace / Crawl Space Installation

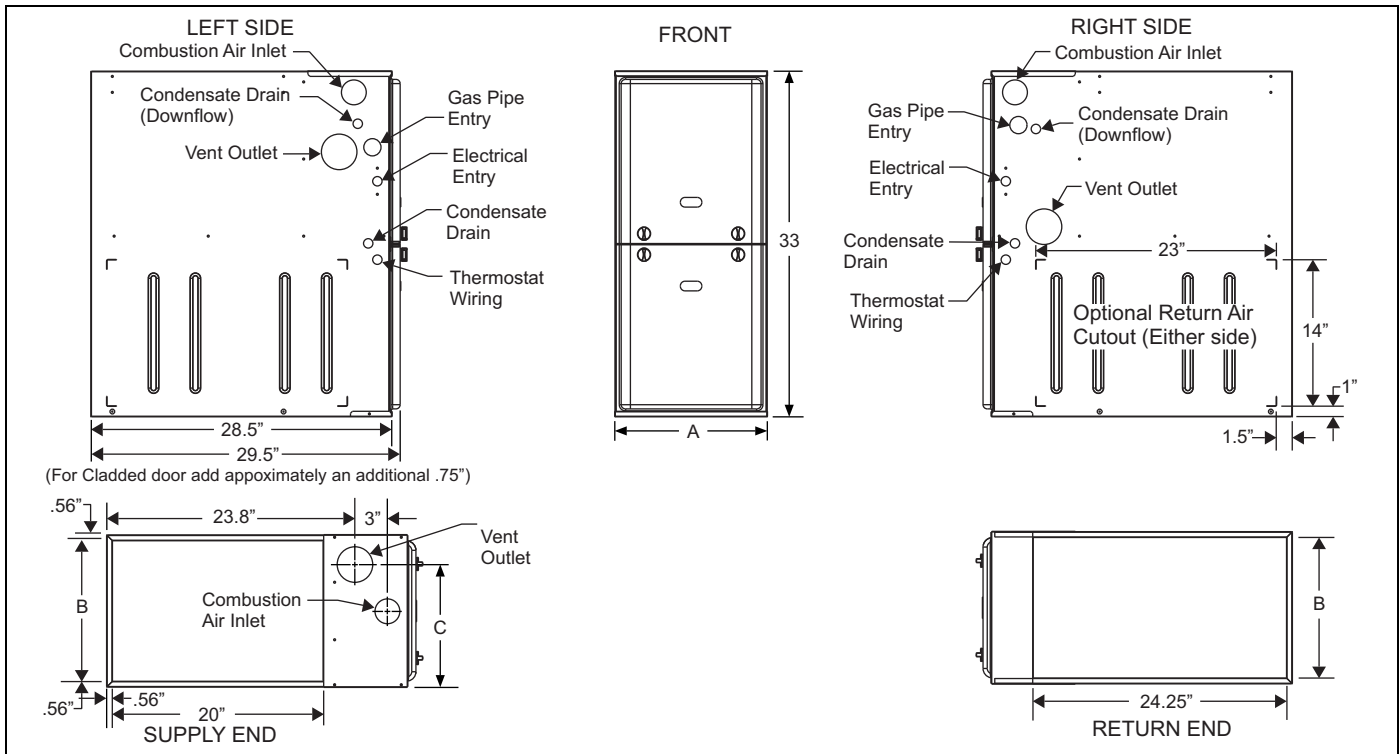

FIGURE 12: Dimensions

Table 3: Cabinet and Duct Dimensions

BTUH (kW) Input	Nominal CFM (m <sup>3</sup> /min)	Cabinet Size	Cabinet Dimensions (Inches)						Approximate Operating Weights
			A (in)	A (cm)	B (in)	B (cm)	C (in)	C (cm)	Lbs (kg)
60 (17.6)	1200 (34.0)	B	17 1/2	44.4	16 3/8	41.6	13 1/4	33.7	122
80 (23.4)	1200 (34.0)	B	17 1/2	44.4	16 3/8	41.6	14 3/4	37.5	126
80 (23.4)	1600 (45.3)	C	21	53.3	19 7/8	50.5	16 1/2	41.9	136
100 (29.3)	1600 (45.3)	C	21	53.3	19 7/8	50.5	18 1/4	46.4	142
100 (29.3)	2000 (56.6)	C	21	53.3	19 7/8	50.5	18 1/4	46.4	145
120 (35.1)	2000 (56.6)	D	24 1/2	62.2	23 3/8	59.4	21 3/4	55.2	156

### SECTION III: FILTERS

#### FILTER INSTALLATION

All applications require the use of a field installed filter. All filters and mounting provision must be field supplied.

Filters must be installed external to the furnace cabinet. **DO NOT attempt to install filters inside the furnace.**

**NOTE:** Single side return above 1800 CFM is approved as long as the filter velocity does not exceed filter manufacturer's recommendation and a transition is used to allow use on a 20x25 filter.

Table 4: Recommended Filter Sizes (High Velocity 600 FPM)

CFM (m <sup>3</sup> /min)	Cabinet Size	Side (in)	Bottom (in)
1200 (34.0)	B	16 x 25	16 x 25
1600 (45.3)	C	16 x 25	20 x 25
2000 (56.6)	C	(2) 16 x 25	20 x 25
2000 (56.6)	D	(2) 16 x 25	22 x 25

**NOTES:**

- Air velocity through throwaway type filters may not exceed 300 feet per minute (91.4 m/min). All velocities over this require the use of high velocity filters.
- Do not exceed 1800 CFM using a single side return and a 16x25 filter. For CFM greater than 1800, you may use two side returns or one side and the bottom or one side return with a transition to allow use of a 20x25 filter.

### SIDE RETURN

Locate the “L” shaped corner locators. These indicate the size of the cutout to be made in the furnace side panel. Refer to Figure 13.

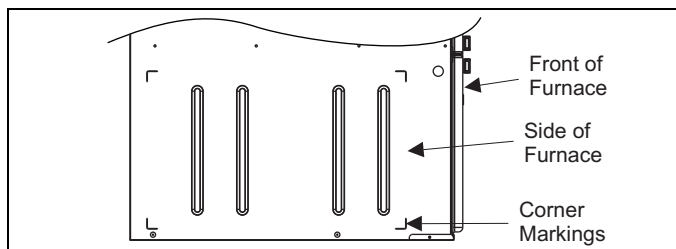

**FIGURE 13:** Side Return Cutout Markings

Install the side filter rack following the instructions provided with that accessory. If a filter(s) is provided at another location in the return air system, the ductwork may be directly attached to the furnace side panel.

**IMPORTANT**

*Some accessories such as electronic air cleaners and pleated media may require a larger side opening. Follow the instructions supplied with that accessory for side opening requirements. **Do not** cut the opening larger than the dimensions shown in Figure 12.*

### HORIZONTAL APPLICATION

#### Horizontal Filters

**CAUTION**

*All filters and mounting provision must be field supplied. All installations must have a filter installed.*

Any branch duct (rectangular or round duct) attached to the plenum must attach to the vertical plenum before the filter. The use of straps and/or supports is required to support the weight of the external filter box.

#### Downflow Filters

Downflow furnaces typically are installed with the filters located above the furnace, extending into the return air plenum or duct. Any branch duct (rectangular or round duct) attached to the plenum must attach to the vertical plenum above the filter height.

Filter(s) may be located in the duct system external to the furnace using an external duct filter box attached to the furnace plenum or at the end of the duct in a return filter grille(s). The use of straps and/or supports is required to support the weight of the external filter box.

## SECTION IV: GAS PIPING

### GAS SAFETY

**DANGER**

*An overpressure protection device, such as a pressure regulator, must be installed in the gas piping system upstream of the furnace and must act to limit the downstream pressure to the gas valve so it does not exceed 0.5 psig [14" w.c. (3.48 kPa)]. Pressures exceeding 0.5 psig [14" w.c. (3.48 kPa)] at the gas valve will cause damage to the gas valve, resulting in a fire or explosion or cause damage to the furnace or some of its components that will result in property damage and loss of life.*

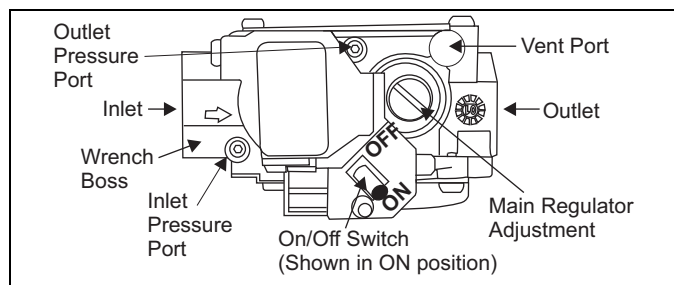

**FIGURE 14:** Gas Valve

**IMPORTANT**

*Plan your gas supply before determining the correct gas pipe entry. Use 90° service elbow(s), or short nipples and conventional 90° elbow(s) to enter through the cabinet access holes.*

### GAS PIPING INSTALLATION

Properly sized wrought iron, approved flexible or steel pipe must be used when making gas connections to the unit. If local codes allow the use of a flexible gas appliance connection, always use a new listed connector. Do not use a connector that has previously serviced another gas appliance.

Some utility companies or local codes require pipe sizes larger than the minimum sizes listed in these instructions and in the codes. The furnace rating plate and the instructions in this section specify the type of gas approved for this furnace - only use those approved gases. The installation of a drip leg and ground union is required. Refer to Figure 15.

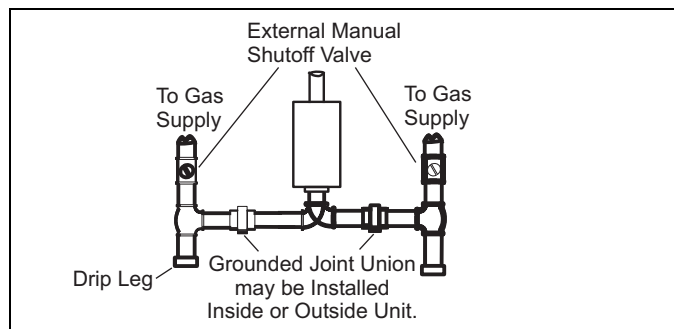

**FIGURE 15:** Upflow/Downflow Gas Piping

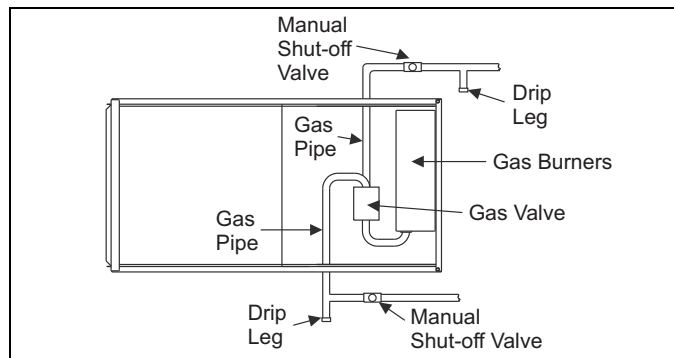

**FIGURE 16:** Horizontal Gas Piping

**IMPORTANT**

*An accessible manual shutoff valve must be installed upstream of the furnace gas controls and within 6 feet (1.8 m) of the furnace.*

The furnace must be isolated from the gas supply piping system by closing its individual external manual shutoff valve during any pressure testing of the gas supply piping system at pressures equal to or less than 0.5 psig (3.5 kPa).

### CAUTION

*The gas valve body is a very thin casting that cannot take any external pressure. Never apply a pipe wrench to the body of the gas valve when installing piping. A wrench must be placed on the octagon hub located on the gas inlet side of the valve. Placing a wrench to the body of the gas valve will damage the valve causing improper operation and/or the valve to leak.*

Gas piping may be connected from either side of the furnace using any of the gas pipe entry knockouts on both sides of the furnace. Refer to Figure 12.

### GAS ORIFICE CONVERSION FOR PROPANE (LP)

This furnace is constructed at the factory for natural gas-fired operation, but may be converted to operate on propane (LP) gas by using a factory-supplied LP conversion kit. Follow the instructions supplied with the LP kit.

### HIGH ALTITUDE GAS ORIFICE CONVERSION

This furnace is constructed at the factory for natural gas-fired operation at 0–5,000 feet (0–1,524 m) above sea level.

The manifold pressure must be changed in order to maintain proper and safe operation when the furnace is installed in a location where the altitude is greater than 5,000 feet (1,524 m) above sea level. Refer to Figure 5 for proper manifold pressure settings.

### HIGH ALTITUDE PRESSURE SWITCH CONVERSION

For installation where the altitude is less than 5,000 feet (1,524m), it is not required that the pressure switch be changed unless you are in an area subject to low pressure inversions.

**Table 5:** Nominal Manifold Pressure - High Fire

Manifold Pressures (in. w.c.)				
		Altitude (feet)		
		0-7999	8000-8999	9000-9999
Gas Heating Value (BTU/cu ft.)	800	3.5	3.5	3.5
	850	3.5	3.5	3.5
	900	3.5	3.5	3.5
	950	3.5	3.5	3.3
	1000	3.5	3.2	2.9
	1050	3.5	2.9	2.7
	1100	3.2	2.7	2.4
	2500 (LP)	9.8	8.2	7.5

Manifold Pressures (kPa)				
		Altitude (m)		
		0-2437	2438-2742	2743-3048
Gas Heating Value (MJ/cu m)	29.8	0.87	0.87	0.87
	31.7	0.87	0.87	0.87
	33.5	0.87	0.87	0.87
	35.4	0.87	0.87	0.81
	37.3	0.87	0.80	0.73
	39.1	0.87	0.73	0.67
	41.0	0.80	0.66	0.61
	93.2 (LP)	2.44	2.03	1.86

### DANGER

#### PROPANE AND HIGH ALTITUDE CONVERSION KITS

*It is very important to choose the correct kit and/or gas orifices for the altitude and the type of gas for which the furnace is being installed.*

*Only use natural gas in furnaces designed for natural gas. Only use propane (LP) gas for furnaces that have been properly converted to use propane (LP) gas. Do not use this furnace with butane gas.*

*Incorrect gas orifices or a furnace that has been improperly converted will create an extremely dangerous condition resulting in premature heat exchanger failure, excessive sooting, high levels of carbon monoxide, personal injury, property damage, a fire hazard and/or death.*

*High altitude and propane (LP) conversions are required in order for the appliance to satisfactorily meet the application.*

*An authorized distributor or dealer must make all gas conversions.*

*In Canada, a certified conversion station or other qualified agency, using factory specified and/or approved parts, must perform the conversion.*

*The installer must take every precaution to insure that the furnace has been converted to the proper gas orifice size when the furnace is installed.*

*Do not attempt to drill out any orifices to obtain the proper orifice size. Drilling out a gas orifice will cause misalignment of the burner flames, causing premature heat exchanger burnout, high levels of carbon monoxide, excessive sooting, a fire hazard, personal injury, property damage and/or death.*

## SECTION V: ELECTRICAL POWER

### ELECTRICAL POWER CONNECTIONS

Field wiring to the unit must be grounded. Electric wires that are field installed shall conform to the temperature limitation for 63°F (35°C) rise wire when installed in accordance with instructions. Refer to Figure 6 in these instructions for specific furnace electrical data.

### CAUTION

*Use copper conductors only.*

**Table 6:** Ratings & Physical / Electrical Data

Input		Output		Nominal Airflow		AFUE %	Air Temp. Rise		Max. Outlet Air Temp		Blower		Blower Size	Max Over-Current Protect	Total Unit Amps	Min. wire Size (awg) @ 75 ft one way
MBH	kW	MBH	kW	CFM	m <sup>3</sup> /min		°F	°C	°F	°C	HP	Amps				
60	17.6	57	16.7	1200	34.0	95.5	30-60	17-33	180	82.2	1/2	6.8	11x8	15	9.5	14
80	23.4	76	22.3	1200	34.0	95.5	40-70	22-39	170	76.7	1/2	6.8	11x8	15	9.5	14
80	23.4	76	22.3	1600	45.3	95.5	35-65	19-36	165	73.9	1/2	6.8	11x10	15	9.5	14
100	29.3	95	27.8	1600	45.3	95.5	40-70	22-39	170	76.7	1/2	6.8	11x10	15	9.5	14
100	29.3	95	27.8	2000	56.6	95.5	35-65	19-36	165	73.9	3/4	8.4	11x11	15	10.9	14
120	35.1	114	33.4	2000	56.6	95.5	45-75	25-42	175	79.4	3/4	8.4	11x11	15	10.9	14

Annual Fuel Utilization Efficiency (AFUE) numbers are determined in accordance with DOE Test procedures.

Wire size and over current protection must comply with the National Electrical Code (NFPA-70-latest edition) and all local codes.

The furnace shall be installed so that the electrical components are protected from water.

## SUPPLY VOLTAGE CONNECTIONS

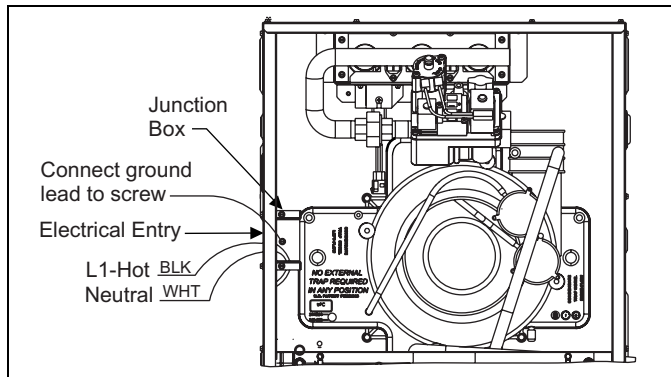

**FIGURE 17:** Electrical Wiring

1. Provide a power supply separate from all other circuits. Install overcurrent protection and disconnect switch per local/national electrical codes. The switch should be close to the unit for convenience in servicing. With the disconnect or fused switch in the OFF position, check all wiring against the unit wiring label. Refer to the wiring diagram in this instruction.
2. Remove the wiring box cover screws. Route all power wiring through a conduit connector or other proper bushing that has been installed into the unit opening and the junction box. In the junction box there is a black wire, a white wire and a green ground screw. Connect the power supply as shown on the unit's wiring label located on the inside of the blower compartment door, or the wiring schematic in this section. Connect the black wire to L1 (hot) from the power supply. Connect the white wire to neutral. Connect the ground wire (installer-supplied) to the green (equipment ground) screw. An alternate wiring method is to use a field-provided 2" (5.1 cm) x 4" (10.2 cm) box and cover on the outside of the furnace. Route the furnace leads into the box using a protective bushing where the wires pass through the furnace panel. After making the wiring connections replace the wiring box cover and screws. Refer to Figure 17.
3. The furnace's control system requires correct polarity of the power supply and a proper ground connection. Refer to Figure 17.

### IMPORTANT

*The power connection leads and wiring box may be relocated to the left side of the furnace. Remove the screws and cut wire tie holding excess wiring. Reposition on the left side of the furnace and fasten using holes provided.*

## LOW VOLTAGE CONTROL WIRING CONNECTIONS

Install the field-supplied thermostat by following the instructions that come with the thermostat. With the thermostat set in the OFF position and the main electrical source disconnected, connect the thermostat wiring from the wiring connections on the thermostat to the terminal board on the ignition module, as shown in Figure 18. Electronic thermostats may require the common wire to be connected. Apply strain relief to thermostat wires passing through cabinet. If air conditioning equipment is installed, use thermostat wiring to connect the Y and C terminals on the furnace control board to the proper wires on the condensing unit (unit outside).

### IMPORTANT

*Set the heat anticipator in the room thermostat to 0.4 amps. Setting it lower will cause short cycles. Setting it higher will cause the room temperature to exceed the set points.*

### IMPORTANT

*Some electronic thermostats do not have adjustable heat anticipators. They should be set to six cycles per hour. Follow the thermostat manufacturer's instructions.*

The 24-volt, 40 VA transformer is sized for the furnace components only, and should not be connected to power auxiliary devices such as humidifiers, air cleaners, etc. The transformer may provide power for an air conditioning unit contactor.

For additional connection diagrams for all UPG equipment refer to "Low Voltage System Wiring" document available on-line at [www.upgnet.com](http://www.upgnet.com) in the Product Catalog Section.

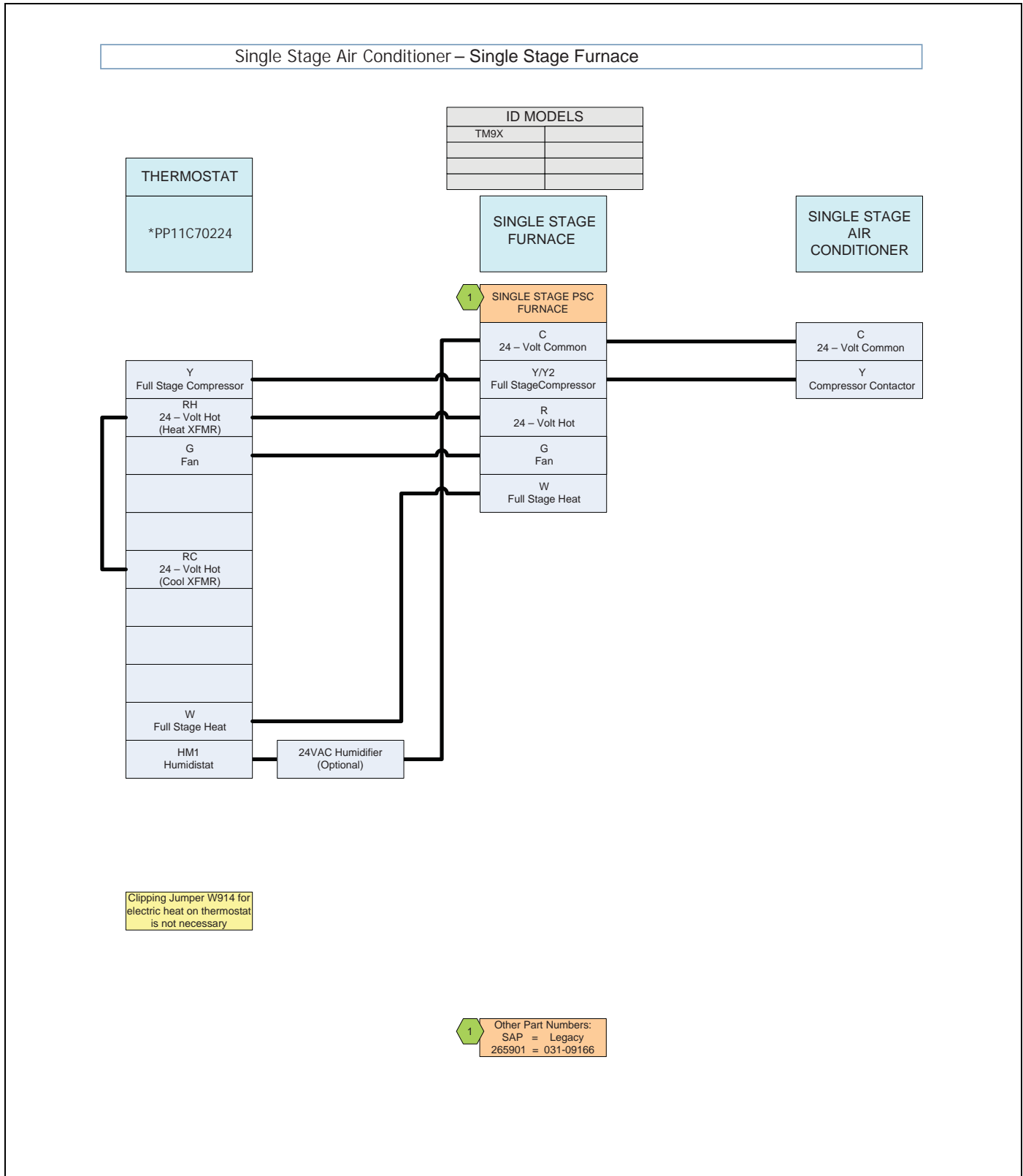

FIGURE 18: Thermostat Chart - Single Stage AC with Single Stage Furnaces

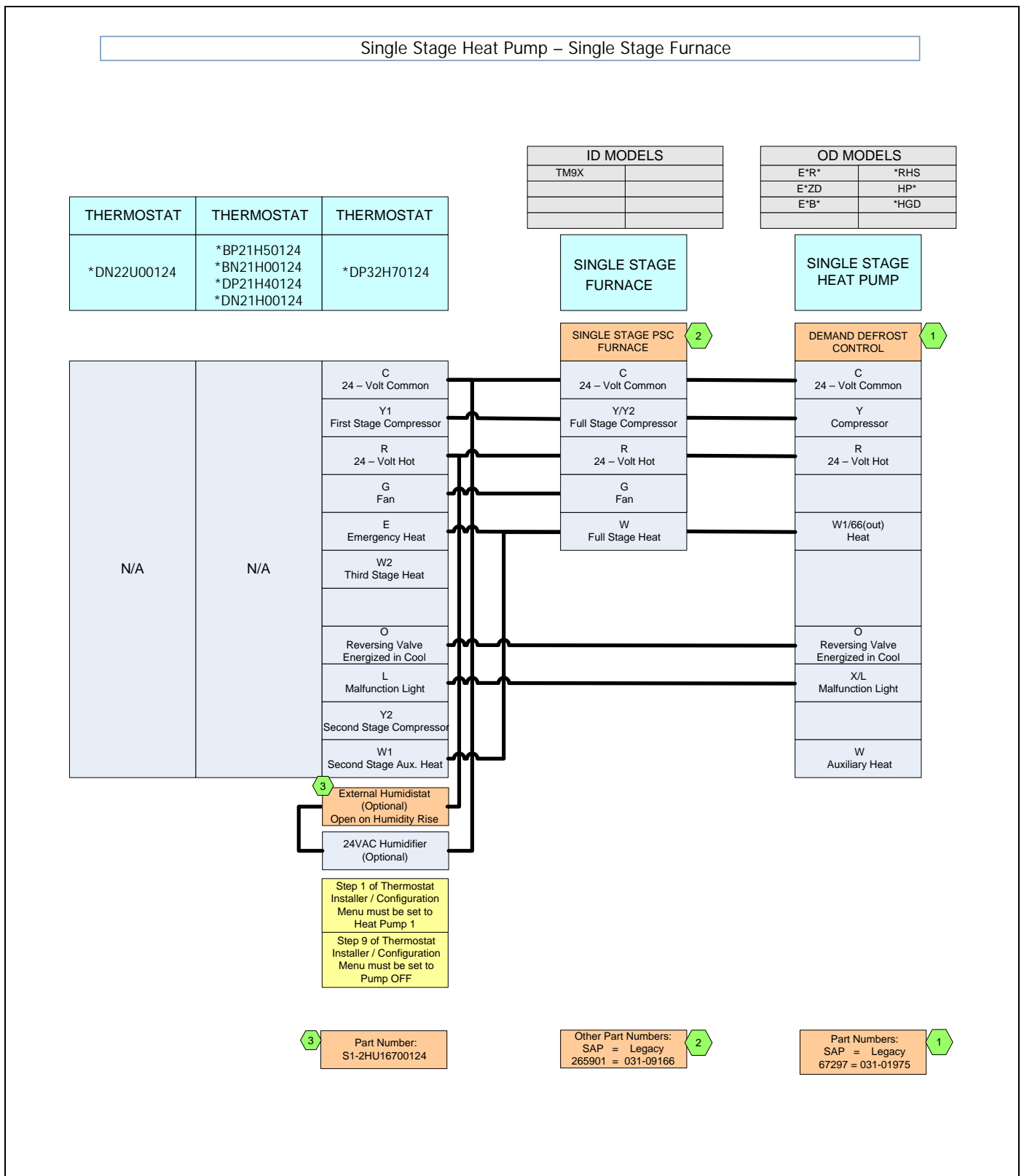

FIGURE 19: Thermostat Chart - Single Stage HP with Single Stage Furnaces

## ACCESSORY CONNECTIONS

The furnace control will allow power-switching control of various accessories.

### ELECTRONIC AIR CLEANER CONNECTION

Two 1/4" (6.4 mm) spade terminals (EAC and NEUTRAL) for electronic air cleaner connections are located on the control board. The terminals provide 115 VAC (1.0 amp maximum) during circulating blower operation.

### HUMIDIFIER CONNECTION

Two 1/4" (6.4 mm) spade terminals (HUM and NEUTRAL) for humidifier connections are located on the control board. The terminals provide 115 VAC (1.0 amp maximum) during heating system operation.

A mounting hole is provided on the control panel next to the furnace control board for mounting a humidifier transformer if required.

## SECTION VI: CONDENSATE PIPING AND FURNACE VENTING CONFIGURATION

### CONDENSATE DRAIN LOCATION

As shipped from the factory:

- For all 060 & 080K input furnaces the main drain is plumbed through the casing right-side opening when viewed from the front of the furnace.
- For all 100, 120K input furnaces the main drain is plumbed through the casing left-side opening when viewed from the front of the furnace.

**NOTE: The Figures 20 - 25 show the condensate drain arrangement for the various possible furnace and vent blower positions.**

The condensate hoses must slope downwards at all points.

***The furnace condensate pan is self priming and contains an internal trap to prevent flue gas leaking. Do not install an external condensate trap.***

When drain hose routing changes are required (shown in Figures 20-25), be sure to cap all un-used openings.

If rerouting hoses - excess length should be cut off so that no sagging loops will collect and hold condensate - which will cause the furnace to not operate.

No hose clamps are needed for connecting to the condensate pan.

## IMPORTANT

*The furnace, evaporator coil, and humidifier drains may be combined and drained together. The evaporator coil drain must have an external, field-supplied trap prior to the furnace drain connection. All drain connections (furnace, evaporator coil, or humidifier) must be terminated into an open or vented drain as close to the respective equipment as possible.*

## IMPORTANT

*Condensate must be disposed of properly. Follow local plumbing or wastewater codes. The drain line must maintain a 1/4" per foot (21 mm/m) downward slope to the drain.*

## IMPORTANT

*If an external vent tee is being installed, then it must have its own condensate trap before it is disposed into an open or vented drain. **This is not to be considered as a second trap as referenced elsewhere in this document.***

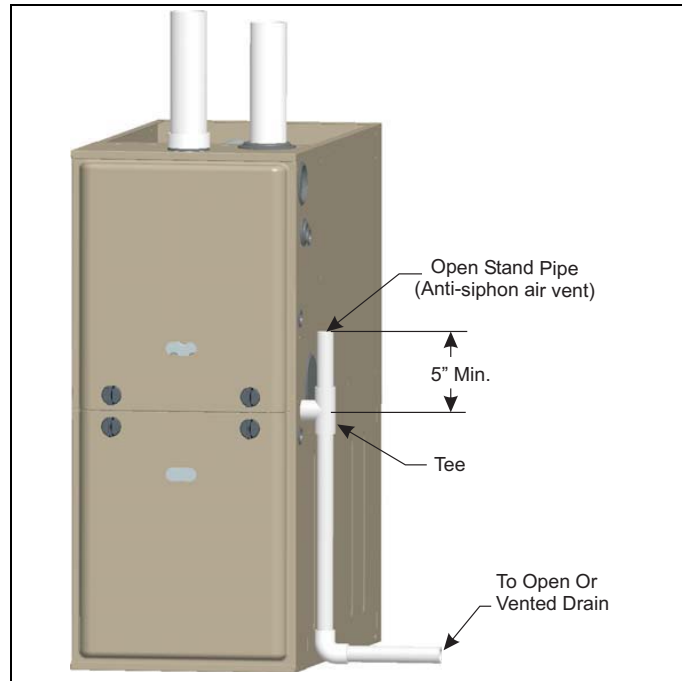

**FIGURE 20:** Typical. Condensate drain, vertical installation.

The condensate will flow to the drain better if an open stand pipe is installed in the drain line. See Figure 20.

If evaporator coil or humidifier drains are combined with the furnace drain, then the open stand pipe could be raised higher, above the 5" minimum.

## CAUTION

*It is possible for condensation to form inside the combustion air (intake) pipe in the summer months if significant length of combustion air pipe passes through conditioned space. This problem can be averted by the addition of a simple drain tee, or a drain tee with a trap on the combustion air pipe as close to the furnace as possible, as shown in Figure 21. This is true for all long horizontal venting in any furnace configuration. This will prevent the condensate from entering the furnace.*

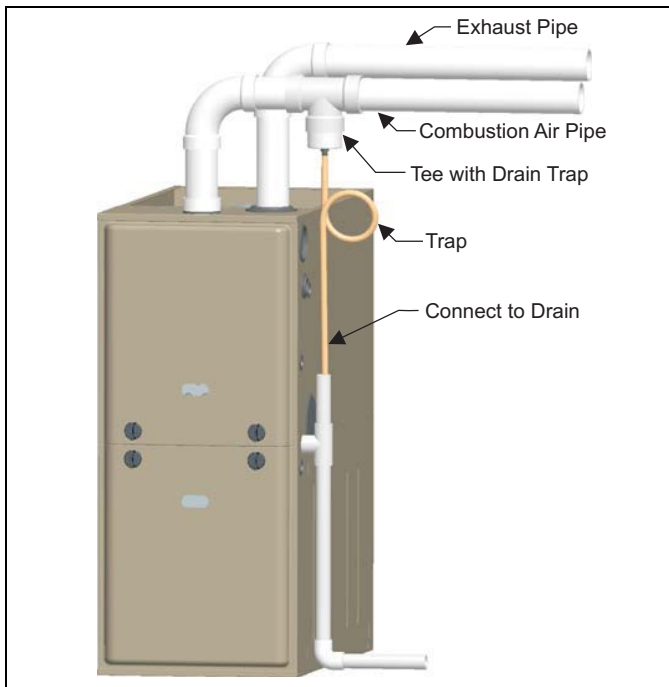

FIGURE 21: Typical. Combustion Pipe Drain Tee.

### CONDENSATE DRAIN TERMINATION

A condensate sump pump **MUST** be used if required by local codes, or if no indoor floor drain is available. The condensate sump pump must be approved for use with acidic condensate.

#### **WARNING**

*DO NOT terminate condensate drain in a chimney, or where the drain line may freeze. The line must terminate at an inside drain to prevent freezing of the condensate and possible property damage. DO NOT trap the drain line at any other location than at the condensate drain trap supplied with the furnace.*

### CONDENSATE DRAIN TRAP AND DRAIN FREEZE PROTECTION

Special precautions **MUST** be made if installing furnace in an area which may drop below freezing. This can cause improper operation or damage to the equipment. If the furnace is installed in an area that has the potential of freezing, the drain line must be protected. Use a 3 to 6 watt per foot at 115 vac, 40°F (4.4°C) self-regulating, shielded and waterproof heat tape. Wrap the drain line outside of the furnace with the heat tape and secure with ties. Follow the heat tape manufacturer's recommendations.

#### **WARNING**

*We have conducted limited freeze tests with the new condensate pans and have not witnessed any issues. **No anti-freeze is approved at this time to be used in the new condensate pans.***

When drain hose routing changes are required, be sure to cap all un-used openings. If rerouting hoses - excess length should be cut off so that no sagging loops will collect and hold condensate, which will cause the furnace to not operate.

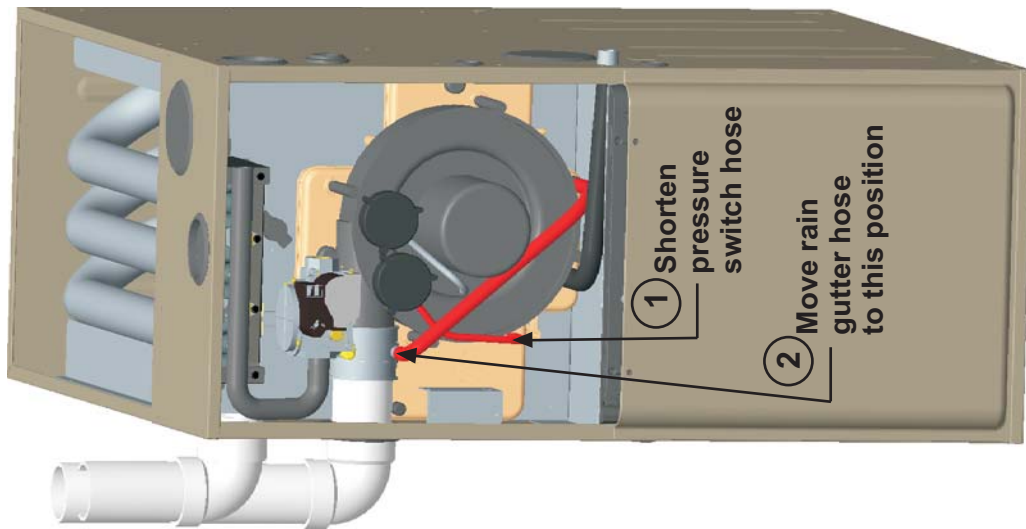

**INDUCER ROTATED FOR LEFT SIDE VENTING**

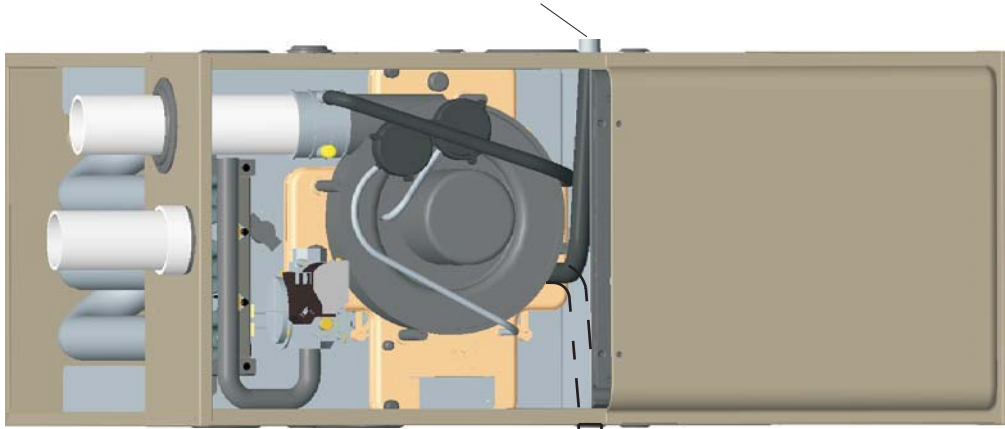

**UPFLOW AS RECEIVED**

For 100 & 120K input furnaces, the condensate drain is plumbed toward the left casing outlet from the factory.

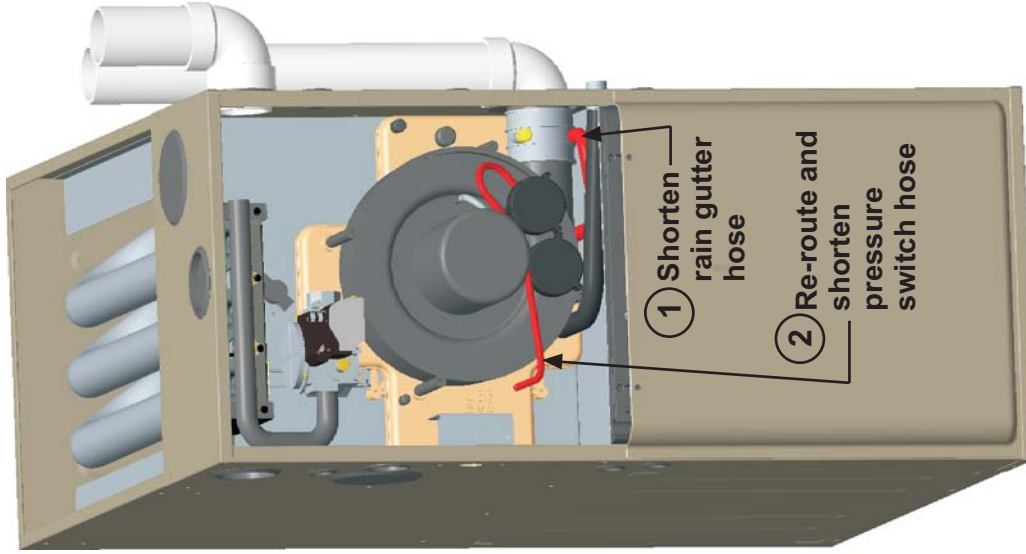

**INDUCER ROTATED FOR RIGHT SIDE VENTING**

For 060 & 080K input furnaces, the condensate drain is plumbed toward the right casing outlet from the factory.

Condensate drain may exit cabinet on either side.

**FIGURE 22:** Upflow Configuration

When drain hose routing changes are required, be sure to cap all un-used openings. If rerouting hoses - excess length should be cut off so that no sagging loops will collect and hold condensate, which will cause the furnace to not operate.

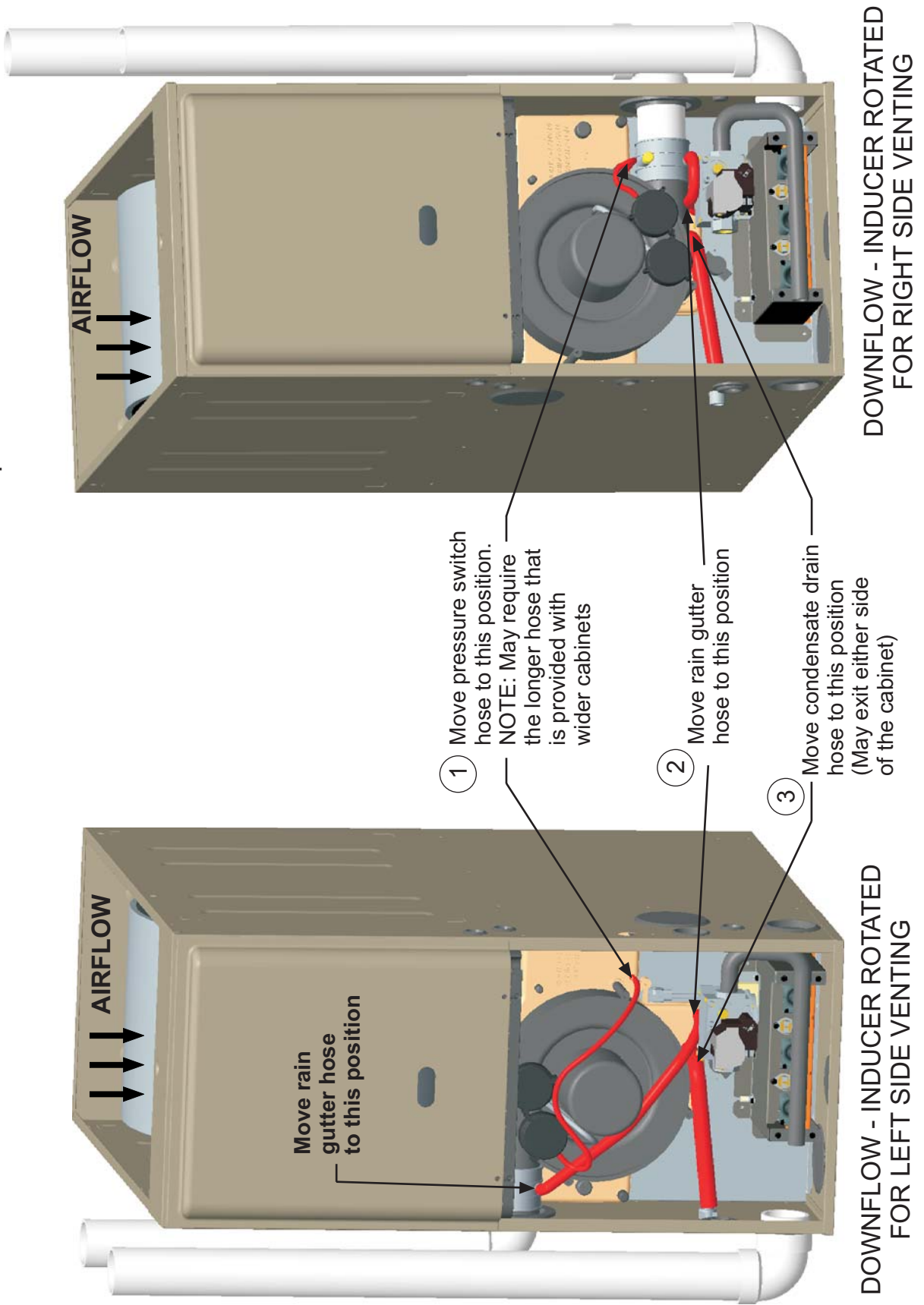

FIGURE 23: Downflow Configuration

When drain hose routing changes are required, be sure to cap all un-used openings. If rerouting hoses - excess length should be cut off so that no sagging loops will collect and hold condensate, which will cause the furnace to not operate.

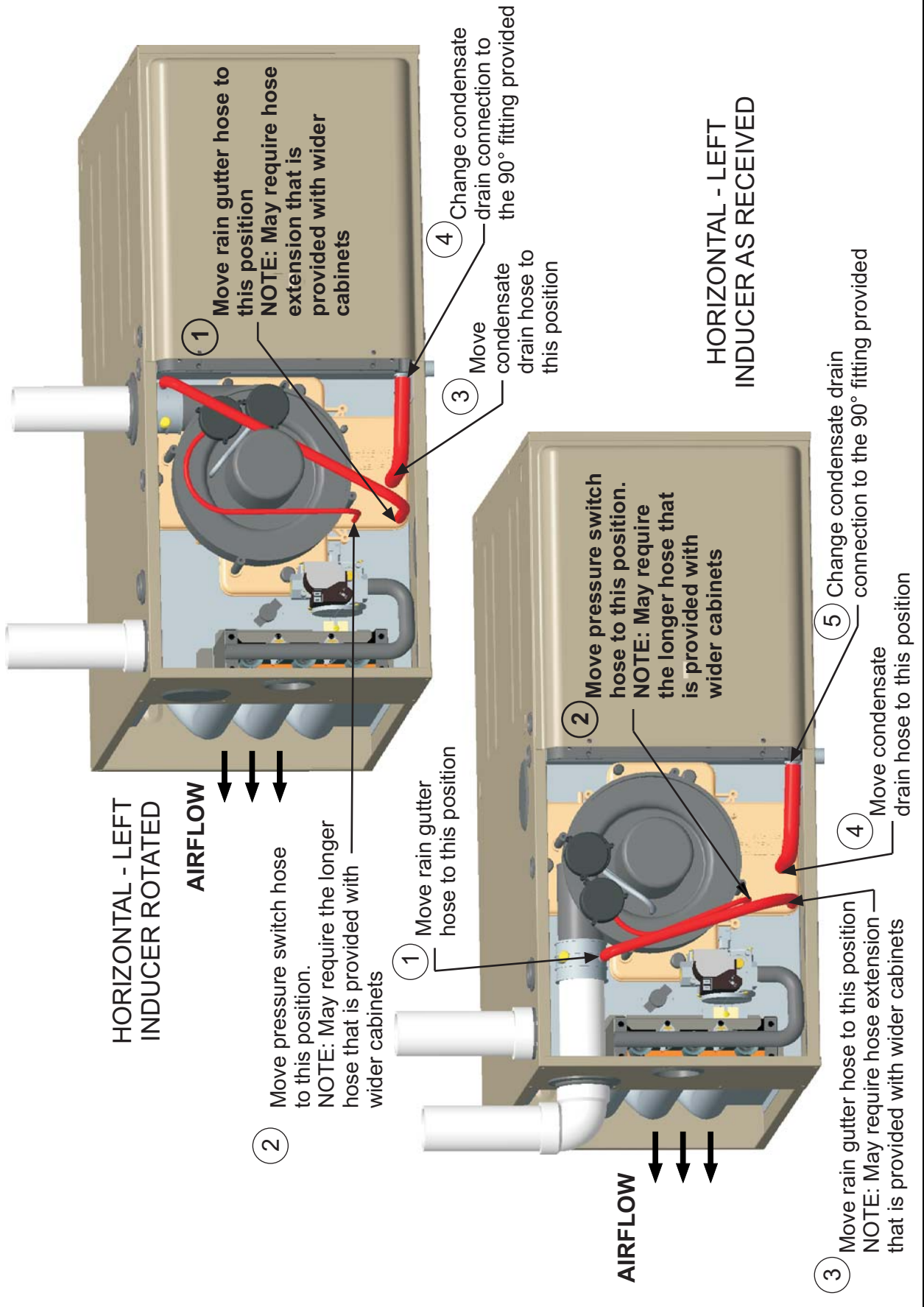

FIGURE 24: Horizontal Left Configuration

When drain hose routing changes are required, be sure to cap all un-used openings. If rerouting hoses - excess length should be cut off so that no sagging loops will collect and hold condensate, which will cause the furnace to not operate.

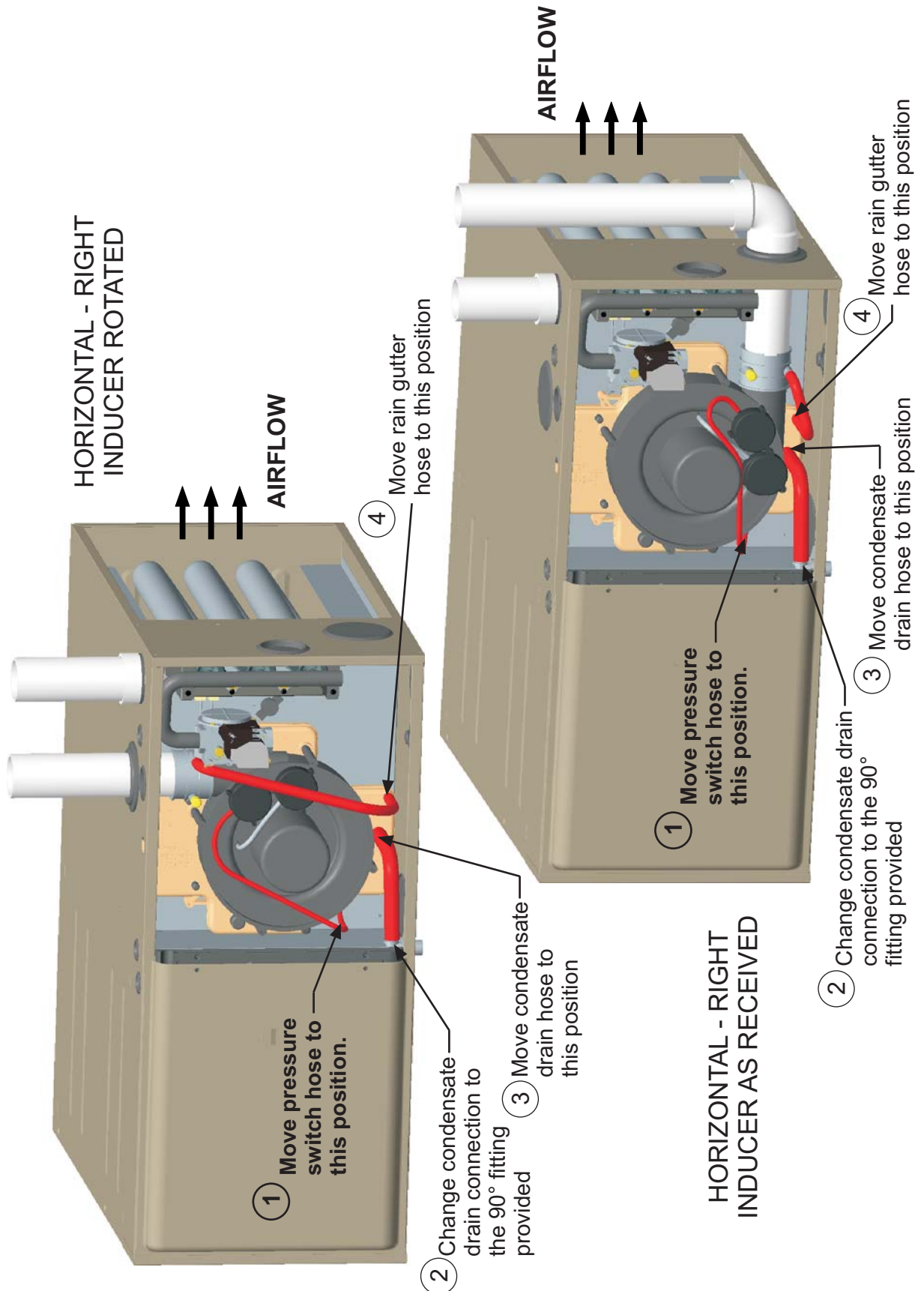

FIGURE 25: Horizontal Right Configuration

## SECTION VII: COMBUSTION AIR AND VENT SYSTEM

### COMBUSTION AIR AND VENT SAFETY

This Category IV, dual certified direct vent furnace is designed for residential application. It may be installed without modification to the condensate system in a basement, garage, equipment room, alcove, attic or any other indoor location where all required clearance to combustibles and other restrictions are met. The combustion air and the venting system must be installed in accordance with Section 5.3, Air for Combustion and Ventilation, of the National Fuel Gas Code Z223.1/NFPA 54 (latest edition), or Sections 7.2, 7.3 or 7.4 of CSA B149.1, National Gas and Propane Codes (latest edition) or applicable provisions of the local building code and these instructions.

#### IMPORTANT

The "VENT SYSTEM" must be installed as specified in these instructions for Residential and non-HUD Modular Homes. The direct vent system is the only configuration that can be installed in a non-HUD Modular Home.

#### WARNING

This furnace may not be common vented with any other appliance, since it requires separate, properly sized air intake and vent lines. The furnace shall not be connected to any type of B, BW or L vent or vent connector, and not connected to any portion of a factory-built or masonry chimney. The furnace shall not be connected to a chimney flue serving a separate appliance designed to burn solid fuel.

#### CAUTION

When combustion air pipe is installed above a suspended ceiling or when it passes through a warm and humid space, the pipe must be insulated with 1/2" Armaflex or other heat resistant type insulation if two feet or more of pipe is exposed. Vent piping must be insulated if it will be subjected to freezing temperatures such as routing through unheated areas or through an unused chimney.

### COMBUSTION AIR/VENT PIPE SIZING

The size of pipe required will be determined by the furnace model, the total length of pipe required and the number of elbows required.

Table 7 lists the maximum equivalent length of pipe allowed for each model of furnace. The equivalent length of elbows is shown in Table 9. The equivalent length of the vent system is the total length of straight pipe PLUS the equivalent length of all of the elbows.

The following rules must also be followed:

1. Long radius (sweep) elbows are recommended. Standard elbows may be used, but since they have a longer equivalent length, they will reduce the total length of pipe that will be allowed. Short radius (plumbing vent) elbows are not allowed. The standard dimensions of the acceptable elbows are shown below.
2. The maximum equivalent length listed in Table 7 is for the vent piping and the air intake piping separately. For example, if the table allows 65 equivalent feet for a particular model, then the vent can have 65 equivalent feet of pipe, AND the combustion air intake can have another 65 equivalent feet of pipe.
3. Three vent terminal elbows (two for the vent and one for the combustion air intake) are already accounted for and need not be included in the equivalent length calculation.

4. All combustion air and vent pipe must conform to American National Standards Institute (ANSI) and American Society for Testing and Materials (ASTM) standards D1785 (Schedule 40 PVC), D2665 (PVC-DWV), F891 (PVC-DWV Cellular Core), D2261 (ABS-DWV) or F628 (Schedule 40 ABS). Pipe cement and primer must conform to ASTM Standard D2546 (PVC) or D2235 (ABS). If ABS pipe is to be used, any joint where ABS pipe is joined to PVC pipe must be glued with cement that is approved for use with BOTH materials. Metallic materials must not be used for venting or air intake.
5. If a flexible connector is used in the vent system, it must be made of a material that is resistant to acidic exposure and to at least 225°F (107°C) temperature. Flexible connectors are also allowed in the combustion air pipe.
6. All models are supplied with 2" (5.1 cm) vent connections. When the pipe must be increased to 3" (7.6 cm) diameter, the transition from 2" to 3" must be done as close to the furnace as possible. For upflow models, the transition from 2" to 3" should be done immediately above the furnace. For downflow or horizontal models, the transition from 2" to 3" pipe should be done immediately after exiting the furnace.
7. In Canada, vents shall be certified to ULC S636, Standard for Type BH Gas Venting Systems. IPEX System 636 PVC is certified to this standard.
8. In Canada, the first three feet (91.4 cm) of the vent must be readily accessible for inspection.
9. For single pipe systems it is recommended to install the combustion air coupling provided and install approximately 18" (46 cm) of PVC pipe on the furnace.
10. Minimum vent length for all models is 5 feet (1.5 m).

TABLE 7: Maximum Equivalent Pipe Length

Model Input BTUH (kW)	Pipe Size Inches (cm)	Maximum Equivalent length feet (m)
60,000 (17.6)	2 (5.1)	65 (19.8)
60,000 (17.6)	3 (7.6)	90 (27.4)
80,000 (23.4)	2 (5.1)	65 (19.8)
80,000 (23.4)	3 (7.6)	90 (27.4)
100,000 (29.3)	2 (5.1)	30 (9.2)
100,000 (29.3)	3 (7.6)	90 (27.4)
120,000 (35.1)	2 (5.1)	30 (9.2)
120,000 (35.1)	3 (7.6)	90 (27.4)

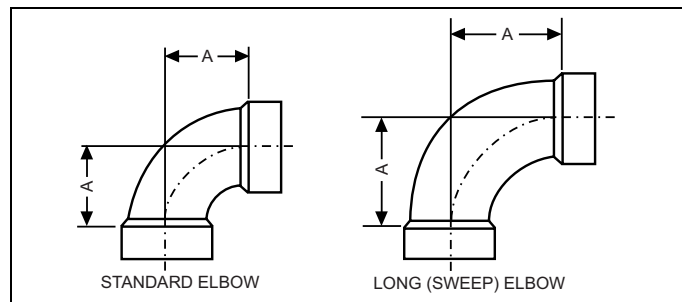

FIGURE 26: Dimensions

TABLE 8: Elbow Dimensions

Elbow "A" Dimension	
2" Standard	2-5/16"
3" Standard	3-1/16"
2" Sweep	3-1/4"
3" Sweep	4-1/16"

Dimensions are those required in Standard ASTM D-3311.

**TABLE 9:** Equivalent Length of Fittings

Fitting	Equivalent Length
2" 90° sweep elbow	5 feet of 2" pipe
2" 45° sweep elbow	2-1/2 feet of 2" pipe
2" 90° standard elbow	10 feet of 2" pipe
2" 45° standard elbow	5 feet of 2" pipe
3" 90° sweep elbow	5 feet of 3" pipe
3" 45° sweep elbow	2-1/2 feet of 3" pipe
3" 90° standard elbow	10 feet of 3" pipe
3" 45° standard elbow	5 feet of 3" pipe
2" corrugated connector	10 feet of 2" pipe
3" corrugated connector	10 feet of 3" pipe

Example:

An 80,000 BTUH furnace requires 32 feet of pipe and four 90° elbows. Using 2" pipe and standard elbows, the total equivalent length will be:

$$\begin{array}{r} 32 \text{ feet of 2" pipe} = 32 \text{ equivalent feet} \\ 4 - 90^\circ \text{ standard 2" elbows} = (4 \times 10) = 40 \text{ equivalent feet} \\ \hline \text{Total} = 72 \text{ equivalent feet of 2" pipe} \end{array}$$

This exceeds the 65 foot maximum equivalent length of 2" pipe allowed for that model and is thus not acceptable.

By using sweep elbows, the total equivalent length will be:

$$\begin{array}{r} 32 \text{ feet of 2" pipe} = 32 \text{ equivalent feet} \\ 4 - 90^\circ \text{ sweep 2" elbows} = (4 \times 5) = 20 \text{ equivalent feet} \\ \hline \text{Total} = 52 \text{ equivalent feet of 2" pipe} \end{array}$$

This is less than the 65 foot maximum equivalent length of 2" pipe allowed for that model and is thus acceptable.

Alternatively, using 3" pipe and standard elbows, the total equivalent length will be:

$$\begin{array}{r} 32 \text{ feet of 3" pipe} = 32 \text{ equivalent feet} \\ 4 - 90^\circ \text{ standard 2" elbows} = (4 \times 5) = 40 \text{ equivalent feet} \\ \hline \text{Total} = 72 \text{ equivalent feet of 3" pipe} \end{array}$$

This is less than the 90 foot maximum equivalent length of 3" pipe allowed for that model and is thus acceptable.

**TABLE 10:** Combustion Air Intake and Vent Connection Size at Furnace (All Models)

FURNACE VENT CONNECTION SIZES		
Furnace Input	60 - 100 MBH (17.6 - 29.3 kW)	120 MBH (35.2 kW)
Intake Pipe Size	2" (5.1 cm)	3" (7.6 cm)
Vent Pipe Size	2" (5.1 cm)	2" (5.1 cm)

\*. Vent pipe size must be increased to 3" diameter after connection to furnace on this model.

**IMPORTANT**

Accessory concentric vent / intake termination kits 1CT0302 and 1CT0303 are available and approved for use with these furnaces. Horizontal sidewall vent terminations kits 1HT0901 & 1HT0902 are also approved for use with these furnaces.

**IMPORTANT**

Furnace vent pipe connections are sized for 2" (5.1 cm) pipe. Any pipe size change must be made outside the furnace casing in a vertical pipe section to allow proper drainage of condensate. An offset using two 45° (degree) elbows will be required for plenum clearance when the vent is increased to 3" (7.6 cm).

**COMBUSTION AIR AND VENT PIPING ASSEMBLY**

The final assembly procedure for the combustion air and vent piping is as follows:

- Cut piping to the proper length beginning at the furnace.
- Deburr the piping inside and outside.
- Chamfer (bevel) the outer edges of the piping.
- Dry-fit the vent piping assembly from the furnace to the outside termination checking for proper fit support and slope.
- Dry-fit the combustion air piping assembly checking for proper fit, support and slope on the following systems:
  - Sealed combustion air systems from the furnace to the outside termination.
  - Ventilated combustion air systems from the furnace to the attic or crawl space termination.

**CAUTION**

Solvent cements are flammable and must be used in well-ventilated areas only. Keep them away from heat, sparks and open flames. Do not breathe vapors and avoid contact with skin and eyes.

- Disassemble the combustion air and vent piping, apply cement primer and the cement per the manufactures instructions. Primer and cement must conform to ASTM D2564 for PVC, or ASTM D2235 for ABS piping.
- All joints must provide a permanent airtight and watertight seal.
- Support the combustion air and vent piping such that it is angled a minimum of 1/4" per foot (21 mm/m) so that condensate will flow back towards the furnace. Piping should be supported with pipe hangers to prevent sagging.
- Seal around the openings where the combustion air and / or vent piping pass through the roof or sidewalls.

**COMBUSTION AIR / VENTING****IMPORTANT**

The vent must be installed with the minimum required clearances, and must comply with local codes and requirements.

## VENT CLEARANCES

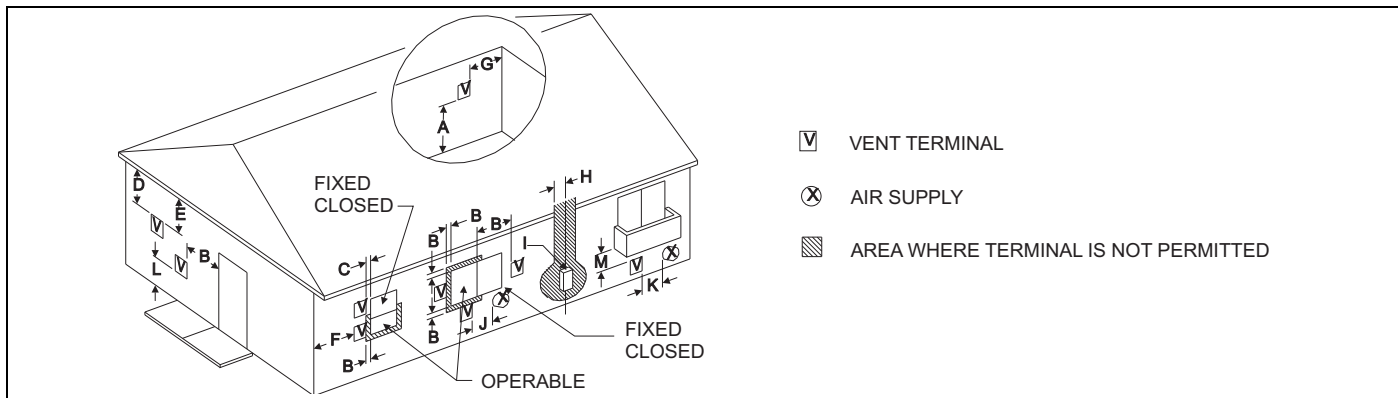

FIGURE 27: Home Layout

Direct Vent Terminal Clearances	Canadian Installations <sup>1,3</sup>	US Installation <sup>2,3</sup>
A. Clearance above grade, veranda, porch, deck, or balcony	12" (30.5 cm)	12" (30.5 cm)
B. Clearance to window or door that may be opened	12" (30.5 cm) for models ≤100,000 BTUH (30 kW), 36" (91.4 cm) for models >100,000 BTUH (30 kW).	Two-pipe (direct vent) applications: 12" (30.5 cm)†† Single-pipe applications: 4 feet (1.2 m).
C. Clearance to permanently closed window	12" (30.5 cm)	12" (30.5 cm)
D. Vertical clearance to ventilated soffit located above the terminal within a horizontal distance of 2 feet (61 cm) from the center line of the terminal	12" (30.5 cm) or in accordance with local installation codes and the requirements of the gas supplier.	12" (30.5 cm) or in accordance with local installation codes and the requirements of the gas supplier.
E. Clearance to unventilated soffit	12" (30.5 cm) or in accordance with local installation codes and the requirements of the gas supplier.	12" (30.5 cm) or in accordance with local installation codes and the requirements of the gas supplier.
F. Clearance to outside corner	12" (30.5 cm) or in accordance with local installation codes and the requirements of the gas supplier.	12" (30.5 cm) or in accordance with local installation codes and the requirements of the gas supplier.
G. Clearance to inside corner	3 feet (91.4 cm)	3 feet (91.4 cm)
H. Clearance to each side of center line extended above meter/regulator assembly	Above a meter/regulator assembly within 3 feet (91.4 cm) horizontally of the vertical center-line of the regulator vent outlet to a maximum vertical distance of 15 feet (4.5 m) above the meter/regulator assembly.	Above a meter/regulator assembly within 3 feet (91.4 cm) horizontally of the vertical center-line of the regulator vent outlet to a maximum vertical distance of 15 feet (4.5 m) above the meter/regulator assembly.
I. Clearance to service regulator vent outlet	3 feet (91.4 cm)	3 feet (91.4 cm) or in accordance with local installation codes and the requirements of the gas supplier.
J. Clearance to non-mechanical air supply inlet to building or the combustion air inlet to any other appliance	12" (30.5 cm) for models ≤100,000 BTUH (30 kW), 36" (91 cm) for models >100,000 BTUH (30 kW).	Two-pipe (direct vent) applications: 12" (30.5 cm) Single-pipe applications: 4 feet (1.2 m).
K. Clearance to a mechanical supply inlet	6 feet (1.83 m)	3 feet (91.4 cm) above if within 10 feet (3 m) horizontally.
L. Clearance above paved sidewalk or paved driveway located on public property	7 feet (2.13 m)†	7 feet (2.13 m) or in accordance with local installation codes and the requirements of the gas supplier.
M. Clearance under veranda, porch, deck, or balcony	12" (30.5 cm)‡	12" (30.5 cm) or in accordance with local installation codes and the requirements of the gas supplier.

1. In accordance with the current CSA B149.1-00, Natural Gas and Propane Installation Code.

2. In accordance with the current ANSI Z223.1 / NFPA 54, National Gas Code.

3. In accordance with the current ANSI Z21.47 \* CSA 2.3 American National Standard.

† A vent shall not terminate directly above a sidewalk or paved driveway that is located between two single family dwellings and serves both dwellings.

†† 12" (30.5 cm) up from the bottom edge of the structure for Two-pipe (direct vent) applications per ANSI Z223.1 / NFPA 54, National Gas Code.

‡ Permitted only if veranda, porch, deck, or balcony is fully open on a minimum of two sides beneath the floor and the distance between the top of the vent termination and the underside of the veranda, porch, or deck is greater than 12" (30.5 cm) as specified in CSA B149.1-00.

A vent shall not terminate less than 12" (30.5 cm) above a grade level.

Any fresh air or make up inlet for dryer or furnace area is considered to be forced air inlet.

Avoid areas where condensate drippage may cause problems such as above planters, patios, or adjacent to windows where steam may cause fogging.

A terminus of a vent shall be fitted with a cap in accordance with the vent manufacturer's installation instructions, or in accordance with the installation instructions for a special venting system.

Responsibility for the provision of proper adequate venting and air supply for application shall rest with the installer.

Vent shall extend high enough above building, or a neighboring obstruction, so that wind from any direction will not create a positive pressure in the vicinity of the vent.

**IMPORTANT**

Consideration must be given for degradation of building materials by flue gases. Sidewall termination may require sealing or shielding of building surfaces with a corrosion resistant material to protect against combustion product corrosion. Consideration must be given to wind direction in order to prevent flue products and/or condensate from being blown against the building surfaces. If a metal shield is used it must be a stainless steel material at a minimum dimension of 20 inches (51 cm). It is recommended that a retaining type collar be used that is attached to the building surface to prevent movement of the vent pipe.

## VENT SYSTEM

This furnace is certified to be installed with one of two possible vent configurations.

1. Horizontal vent system. This vent system can be installed completely horizontal or combinations of horizontal, vertical, or offset using elbows.
2. Vertical vent system. This vent system can be installed completely vertical or a combination of horizontal, vertical, or offset using elbows.

## VENT APPLICATIONS AND TERMINATION

When selecting the location for a combustion air / vent termination, the following should be considered:

1. Observe all clearances listed in vent clearances in these instructions.
2. Termination should be positioned where vent vapors will not damage plants or shrubs or air conditioning equipment.
3. Termination should be located where it will not be affected by wind gusts, light snow, airborne leaves or allow recirculation of flue gases.
4. Termination should be located where it will not be damaged or exposed to flying stones, balls, etc.
5. Termination should be positioned where vent vapors are not objectionable.
6. Horizontal portions of the vent system must slope upwards and be supported to prevent sagging.
7. Direct vent systems must be installed so the vent and the combustion air pipes terminate in the same atmospheric zone. Refer to Figures 28 or 30.

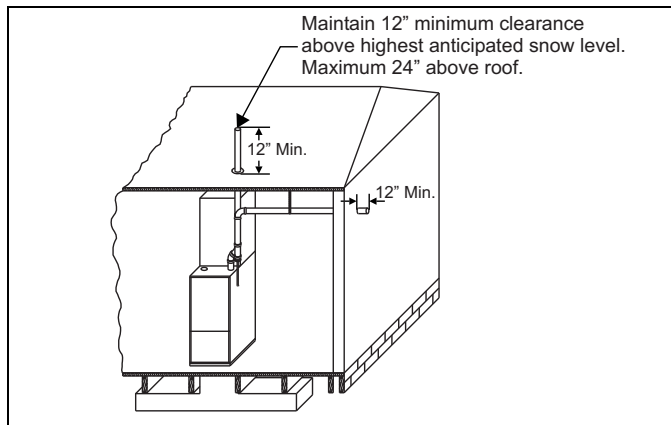

FIGURE 28: Termination Configuration - 1 Pipe

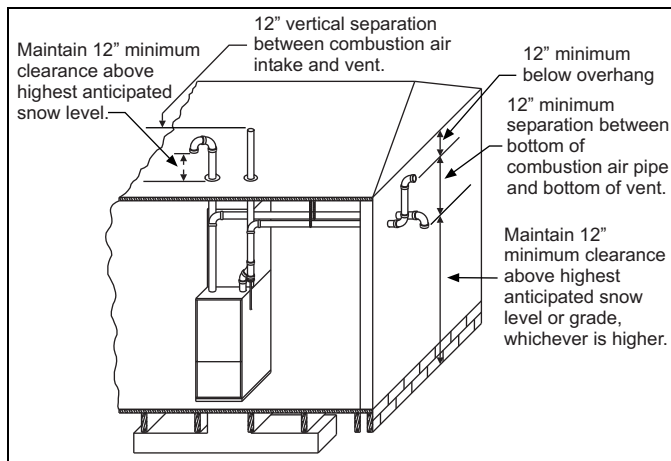

FIGURE 29: Termination Configuration - 2 Pipe

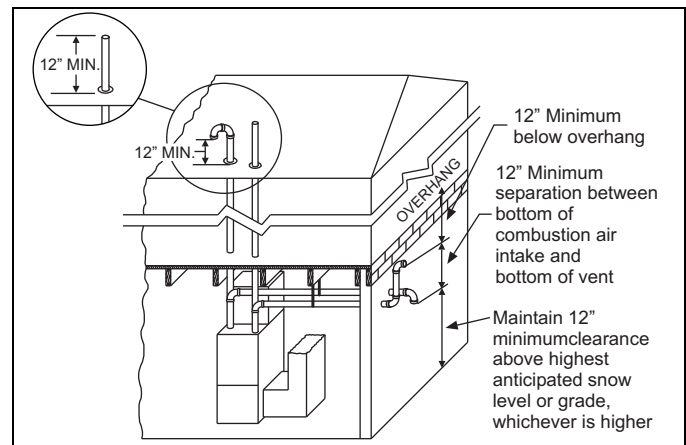

FIGURE 30: Termination Configuration - 2 Pipe Basement

## VENTING MULTIPLE UNITS

Multiple units can be installed in a space or structure as either a single pipe configuration or a two-pipe configuration.

The combustion air side of the single pipe configuration shown in Figure 28 is referred to in these instructions as ambient combustion air supply. Follow the instructions for ambient combustion air installations, paying particular attention to the section on air source from inside the building. The vent for a single pipe system must be installed as specified in the venting section of these instructions with the vent terminating as shown in Figure 28. Each furnace must have a separate vent pipe. Under NO circumstances can the two vent pipes be tied together.

The combustion air side of the two-pipe configuration shown in Figure 29 can be installed so the combustion air pipe terminates as described in outdoor combustion air or ventilated combustion air sections in these instructions. Follow the instructions for outdoor combustion air or ventilated combustion air and the instructions for installing the vent system with the vent terminating as shown in Figures 31 or 32. The two-pipe system must have a separate combustion air pipe and a separate vent pipe for each furnace. Under NO circumstances can the two combustion air or vent pipes be tied together. The combustion air and vent pipes must terminate in the same atmospheric zone.

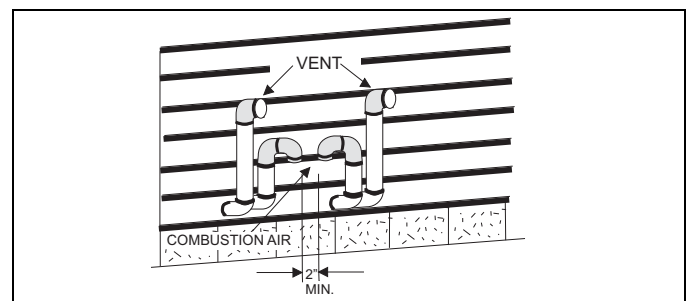

FIGURE 31: Double Horizontal Combustion Air Intake and Vent Termination

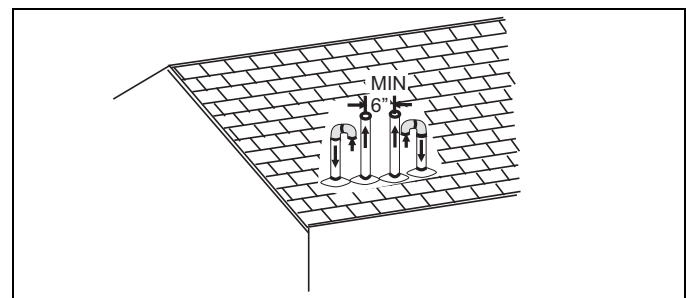

FIGURE 32: Double Vertical Combustion Air Intake and Vent Termination

## COMBUSTION AIR SUPPLY

All installations must comply with Section 5.3, Air for Combustion and Ventilation of the National Fuel Gas Code, ANSI Z223.1 or Sections 7.2, 7.3 or 7.4 of CAN/CGA B149.1 or .2 Installation Code - latest editions.

This furnace is certified to be installed with one of three possible combustion air intake configurations.

1. **OUTDOOR COMBUSTION AIR:** This is a direct vent configuration where the combustion air is supplied through a PVC or ABS pipe that is connected to the PVC coupling attached to the furnace and is terminated in the same atmospheric zone as the vent. This type of installation is approved on all models. Refer to Figure 35.
2. **AMBIENT COMBUSTION AIR:** Combustion air is supplied from the area surrounding the furnace through openings in the furnace casing. The combustion air and the vent pipes are not terminated in the same atmospheric zone. Refer to Figures 28 - 32 for vent terminations. Refer to "Ambient Combustion Air Supply" for proper installation. Refer to Figure 35.
3. **VENTILATED COMBUSTION AIR:** Combustion air is supplied through a PVC or ABS pipe that is connected to the PVC coupling attached to the burner box and is terminated in a ventilated attic or crawl space. The combustion air and the vent pipes are not terminated in the same atmospheric zone. Refer to Figure 36 for attic and crawl space termination. Only the combustion air intake may terminate in the attic. The vent must terminate outside.

### Outdoor Combustion Air

#### Combustion Air Intake/Vent Connections

This installation requires combustion air to be brought in from outdoors. This requires a properly sized pipe (Shown in Figure 29) that will bring air in from the outdoors to the furnace combustion air intake collar on the burner box. The second pipe (Shown in Figure 29) is the furnace vent pipe.

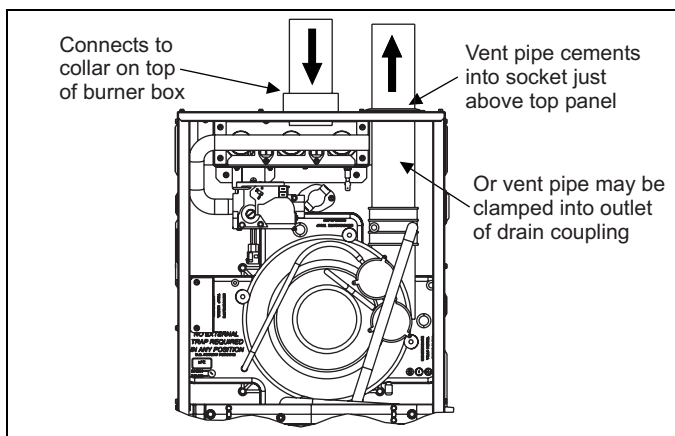

FIGURE 33: Direct Vent Air Intake Connection and Vent Connection

The combustion air intake pipe should be located either through the wall (horizontal or side vent) or through the roof (vertical vent). Care should be taken to locate side vented systems where trees or shrubs will not block or restrict supply air from entering the terminal.

Also, the terminal assembly should be located as far as possible from a swimming pool or a location where swimming pool chemicals might be stored. Be sure the terminal assembly follows the outdoor clearances listed in Section #1 "Outdoor Air Contaminants."

#### Ambient Combustion Air Supply

This type installation will draw the air required for combustion from within the space surrounding the appliance and from areas or rooms adjacent to the space surrounding the appliance. This may be from within the space in a non-confined location or it may be brought into the furnace area from outdoors through permanent openings or ducts. It is not piped directly into the furnace. A single, properly sized pipe from the furnace vent connector to the outdoors must be provided. It is recom-

mended that the supplied intake coupling & 18" of pipe be attached to the furnace to prevent accidental blockage of the combustion air intake.

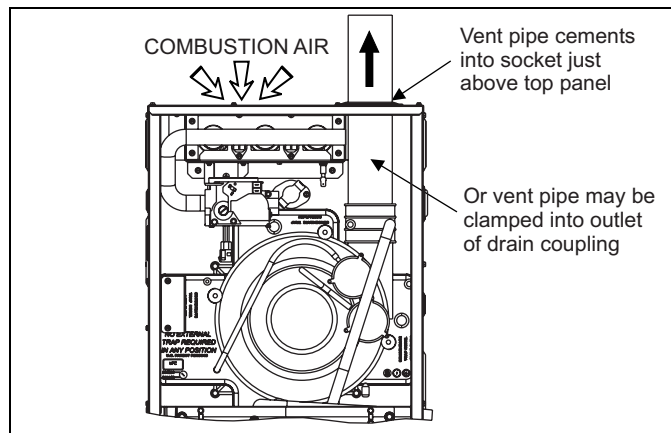

FIGURE 34: Combustion Airflow Path Through The Furnace Casing

## WARNING

*This type of installation requires that the supply air to the appliance(s) be of a sufficient amount to support all of the appliance(s) in the area. Operation of a mechanical exhaust, such as an exhaust fan, kitchen ventilation system, clothes dryer or fireplace may create conditions requiring special attention to avoid unsatisfactory operation of gas appliances. A venting problem or a lack of supply air will result in a hazardous condition, which can cause the appliance to soot and generate dangerous levels of CARBON MONOXIDE, which can lead to serious injury, property damage and / or death.*

An **unconfined space** is not less than 50 cu.ft (1.42 m<sup>3</sup>) per 1,000 BTU/hr (0.293 kW/h) input rating for all of the appliances installed in that area.

Rooms communicating directly with the space containing the appliances are considered part of the unconfined space, if doors are furnished with openings or louvers.

A **confined space** is an area with less than 50 cu.ft (1.42 m<sup>3</sup>) per 1,000 BTU/hr (0.293 kW/h) input rating for all of the appliances installed in that area. The following must be considered to obtain proper air for combustion and ventilation in confined spaces.

#### Combustion Air Source From Outdoors

The blocking effects of louvers, grilles and screens must be given consideration in calculating free area. If the free area of a specific louver or grille is not known, refer to Table 11, to estimate free area.

Table 11: Estimated Free Area

Wood or Metal Louvers or Grilles	Wood 20-25%* Metal 60-70% *
Screens+	1/4" (6.4 mm) mesh or larger 100%

\* Do not use less than 1/4" (6.4 mm) mesh

+ Free area of louvers and grille varies widely; the installer should follow louver or grille manufacturer's instructions.

#### Dampers, Louvers and Grilles (Canada Only)

1. The free area of a supply air opening shall be calculated by subtracting the blockage area of all fixed louvers grilles or screens from the gross area of the opening.
2. Apertures in a fixed louver, a grille, or screen shall have no dimension smaller than 1/4" (6.4 mm).
3. A manually operated damper or manually adjustable louvers are not permitted for use.
4. A automatically operated damper or automatically adjustable louvers shall be interlocked so that the main burner cannot operate unless either the damper or the louver is in the fully open position.

## ⚠ WARNING

When a Category I furnace is removed or replaced, the original venting system may no longer be correctly sized to properly vent the attached appliances.

An improperly sized vent system can cause CARBON MONOXIDE to spill into the living space causing personal injury, and or death.

**Table 12:** Unconfined Space Minimum Area in Square Inch

BTUH Input Rating	Minimum Free Area in Square Feet Required for Each Opening
60,000	60 (387 cm <sup>2</sup> )
80,000	80 (516 cm <sup>2</sup> )
100,000	100 (645 cm <sup>2</sup> )
120,000	120 (742 cm <sup>2</sup> )

**Table 13:** Free Area

BTUH Input Rating	Minimum Free Area Required for Each Opening		
	Horizontal Duct (2,000 BTUH)	Vertical Duct or Opening to Outside (4,000 BTUH)	Round Duct (4,000 BTUH)
60,000	30 in <sup>2</sup> (193 cm <sup>2</sup> )	15 in <sup>2</sup> (97 cm <sup>2</sup> )	5" (13 cm)
80,000	40 in <sup>2</sup> (258 cm <sup>2</sup> )	20 in <sup>2</sup> (129 cm <sup>2</sup> )	5" (13 cm)
100,000	50 in <sup>2</sup> (322 cm <sup>2</sup> )	25 in <sup>2</sup> (161 cm <sup>2</sup> )	6" (15 cm)
120,000	60 in <sup>2</sup> (387 cm <sup>2</sup> )	30 in <sup>2</sup> (193 cm <sup>2</sup> )	7" (18 cm)

EXAMPLE: Determining Free Area.

Appliance	1 Appliance	2 Total Input
100,000	+ 30,000 = (130,000 ÷ 4,000) = 32.5 Sq. In. Vertical	
Appliance	1 Appliance	2 Total Input
100,000	+ 30,000 = (130,000 ÷ 2,000) = 65 Sq. In. Horizontal	

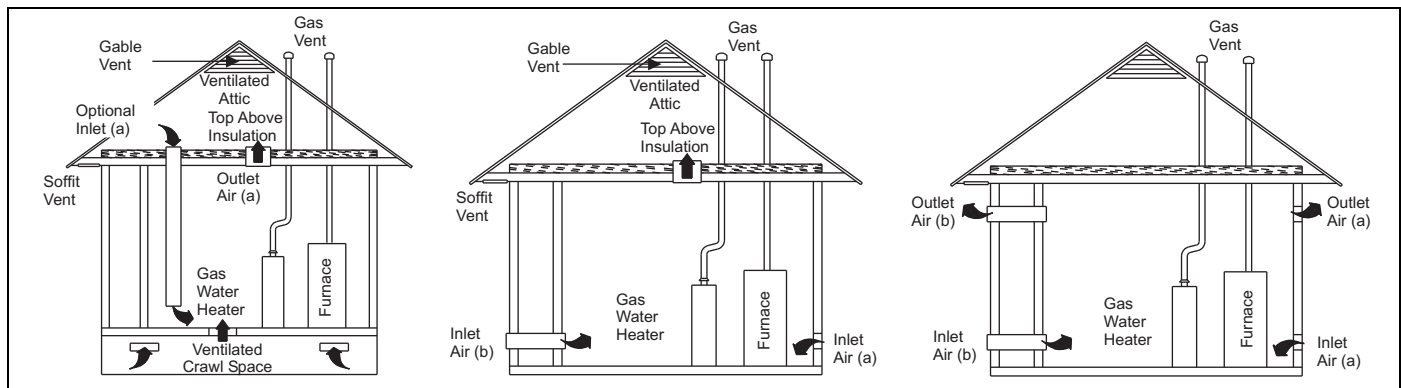

**FIGURE 35:** Outside and Ambient Combustion Air

### Air Supply Openings and Ducts

- An opening may be used in lieu of a duct to provide the outside air supply to an appliance unless otherwise permitted by the authority having jurisdiction. The opening shall be located within 12" (30.5 cm) horizontally from the burner level of the appliance. Refer to "AIR SOURCE FROM OUTDOORS AND VENT AND SUPPLY AIR SAFETY CHECK" in these instructions for additional information and safety check procedure.
- The duct shall be either metal, or a material meeting the class 1 requirements of CAN4-S110 Standard for Air Ducts.
- The duct shall be least the same cross-sectional area as the free area of the air supply inlet opening to which it connects.
- The duct shall terminate within 12" (30.5 cm) above, and within 24" (61 cm) horizontally from, the burner level of the appliance having the largest input.
- A square or rectangular shaped duct shall only be used when the required free area of the supply opening is 9 in<sup>2</sup> (58.06 cm<sup>2</sup>) or larger. When a square or rectangular duct is used, its small dimension shall not be less than 3" (7.6 cm).
- An air inlet supply from outdoors shall be equipped with a means to prevent the direct entry of rain and wind. Such means shall not reduce the required free area of the air supply opening.

- An air supply inlet opening from the outdoors shall be located not less than 12" (30.5 cm) above the outside grade level.

### Combustion Air Source from Outdoors

- Two permanent openings, one within 12" (30.5 cm) of the top and one within 12" (30.5 cm) of bottom of the confined space, Two permanent openings, shall communicate directly or by means of ducts with the outdoors, crawl spaces or attic spaces.
- One permanent openings, commencing within 12" (30.5 cm) of the top of the enclosure shall be permitted where the equipment has clearances of at least 1" (2.54 cm) from the sides and back and 6" (15.2 cm) from the front of the appliance. The opening shall communicate directly with the outdoors and shall have a minimum free area of:
  - 1 square inch per 3000 BTU per hour (322 cm<sup>2</sup> per 0.879 kW) of the total input rating of all equipment located in the enclosure.
  - Not less than the sum of all vent connectors in the confined space.
- The duct shall be least the same cross-sectional area as the free area of the air supply inlet opening to which it connects.
- The blocking effects of louvers, grilles and screens must be given consideration in calculating free area. If the free area of a specific louver or grille is not known. Refer to Table 11.

### Ventilated Combustion Air

The ventilated attic space or a crawl space from which the combustion air is taken must comply with the requirements specified in "AIR SOURCE FROM OUTDOORS" in this instruction or in Section 5.3, Air for Combustion and Ventilation of the National Fuel Gas Code, ANSI Z223.1 (latest edition). This type installation requires two properly sized pipes. One brings combustion air from a properly ventilated attic space or crawl space and a second pipe that extends from the furnace vent connection (top right of unit) to the exterior of the building. Refer to Table 7 for intake pipe sizing, allowable length and elbow usage. Follow all notes, procedures and required materials in the "COMBUSTION AIR/VENT PIPE SIZING" section in these instructions when installing the combustion air pipe from the unit and into a ventilated attic space or crawl space. DO NOT terminate vent pipe in an Attic or Crawl Space.

### Ventilated Combustion Air Termination

Refer to Figure 36 for required attic termination for the combustion air intake pipe. For attic termination, use two 90 elbows with the open end in a downward position. Be sure to maintain 12" (30.5 cm) clearance above any insulation, flooring or other material.

A crawl space combustion air installation consists of a straight pipe from the PVC coupling on the burner box that extends into the crawl space and terminates with a 1/4" (6.4 mm) mesh screen and no elbows.

## WARNING

### CARBON MONOXIDE POISONING HAZARD

Failure to follow the steps outlined below for each appliance connected to the venting system being placed into operation could result in carbon-monoxide poisoning or death.

The following steps shall be followed for each appliance connected to the venting system being placed into operation, while all other appliances connected to the venting system are not in operation:

1. Inspect the venting system for proper size and horizontal pitch. Determine that there is no blockage, restriction, leakage, corrosion or other deficiencies, which could cause an unsafe condition
2. Close all building doors and windows and all doors.
3. Turn on clothes dryers and TURN ON any exhaust fans, such as range hoods and bathroom exhausts, so they shall operate at maximum speed. Open the fireplace dampers. Do not operate a summer exhaust fan.
4. Follow the lighting instructions. Place the appliance being inspected in operation. Adjust thermostat so the appliance shall operate continuously.
5. Test each appliance (such as a water heater) equipped with a draft hood for spillage (down-draft or no draft) at the draft hood relief opening after 5 minutes of main burner operation. Appliances that do not have draft hoods need to be checked at the vent pipe as close to the appliance as possible. Use a combustion analyzer to check the CO<sub>2</sub> and CO levels of each appliance. Use a draft gauge to check for a downdraft or inadequate draft condition.
6. After it has been determined that each appliance properly vents when tested as outlined above, return doors, windows, exhaust fans, fireplace dampers and any other gas burning appliance to their normal condition.
7. If improper venting is observed during any of the above tests, a problem exists with either the venting system or the appliance does not have enough combustion air (Supply Air from outside) to complete combustion. This condition must be corrected before the appliance can function safely.

**NOTE:** An unsafe condition exists when the CO reading exceeds 40 ppm and the draft reading is not in excess of - 0.1" w.c. (-25 kPa) with all of the appliance(s) operating at the same time.

8. Any corrections to the venting system and / or to the supply (outside) air system must be in accordance with the National Fuel Gas Code Z223.1 or CAN/CGA B149.1 Natural Gas and Propane Installation Code (latest editions). If the vent system must be resized, follow the appropriate tables in Appendix G of the above codes or for this appliance.

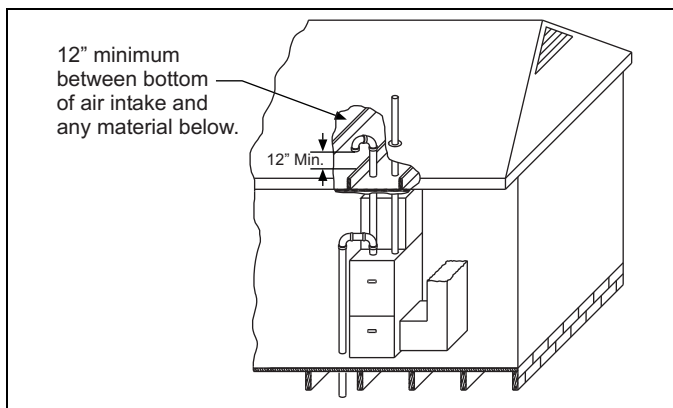

FIGURE 36: Attic and Crawl Space Combustion Air Termination

### Specially Engineered Installations

The above requirements shall be permitted to be waived where special engineering, approved by the authority having jurisdiction, provides an adequate supply of air for combustion and ventilation.

## WARNING

Be sure to instruct the owner not to block this intake pipe.

### VENT BLOWER ROTATION

For ease of venting, the vent blower may be rotated 90° in either direction. For upflow installations the vent may exit through the top or either side of the cabinet. For downflow installations, the vent blower must be rotated so that the vent exits through either side of the cabinet. See Figures 22-25 for details.

## SECTION VIII: START-UP AND ADJUSTMENTS

The initial start-up of the furnace requires the following additional procedures:

### IMPORTANT

*All electrical connections made in the field and in the factory should be checked for proper tightness.*

When the gas supply is initially connected to the furnace, the gas piping may be full of air. In order to purge this air, it is recommended that the ground union be loosened until the odor of gas is detected. When gas is detected, immediately retighten the union and check for leaks. Allow five minutes for any gas to dissipate before continuing with the start-up procedure. Be sure proper ventilation is available to dilute and carry away any vented gas.

### GAS PIPING LEAK CHECK

### WARNING

#### **FIRE OR EXPLOSION HAZARD**

*Failure to follow the safety warnings exactly could result in serious injury, death or property damage.*

*Never test for gas leaks with an open flame. Use a commercially available soap solution made specifically for the detection of leaks to check all connections. A fire or explosion may result causing property damage, personal injury or loss of life.*

### IMPORTANT

*Burner ignition may not be satisfactory on first startup due to residual air in the gas line or until gas manifold pressure is adjusted. The ignition control will make three attempts to light before locking out.*

It is recommended that when the gas supply is first connected to the furnace, the ground union be loosened until the odor of gas is detected. When gas is detected, immediately tighten the union and check for gas leaks. Allow five minutes for any gas to dissipate before continuing with the startup procedure. Be sure that proper ventilation is available to dilute and carry away any vented gas.

With furnace in operation, check all of the pipe joints, gas valve connections and manual valve connections for leakage using an approved gas detector, a non-corrosive leak detection fluid or other leak detection methods. Take appropriate action to stop any leak. If a leak persists, replace the faulty component.

The furnace and its equipment shutoff valve must be disconnected from the gas supply during any pressure testing of that system at test pressures in excess of 0.5 psig (3.45 kPa).

The furnace must be isolated from the gas supply piping system by closing the equipment shutoff valve during any pressure testing of the gas supply system.

## IGNITION SYSTEM SEQUENCE

1. Turn the gas supply ON at external valve and main gas valve.
2. Set the thermostat above room temperature to call for heat.
3. System start-up will occur as follows:
  - a. The induced draft blower motor will start and come up to speed. Shortly after inducer start-up, the hot surface igniter will glow for about 17 seconds.
  - b. After this warm up, the ignition module will energize (open) the main gas valve.
  - c. After flame is established, the supply air blower will start in about 30 seconds.

## CALCULATING THE FURNACE INPUT (NATURAL GAS)

Burner orifices are sized to provide proper input rate using natural gas with a heating value of 1030 BTU/Ft<sup>3</sup> (38.4 MJ/m<sup>3</sup>). If the heating value of your gas is significantly different, it may be necessary to replace the orifices.

**NOTE: DO NOT** set manifold pressure less than 3.2" w.c. or more than 3.8" w.c. for natural gas at sea level. If manifold pressure is outside this range, change main burner orifices.

**NOTE:** If orifice hole appears damaged or it is suspected to have been redrilled, check orifice hole with a numbered drill bit of correct size. Never redrill an orifice. A burr-free and squarely aligned orifice hole is essential for proper flame characteristics.

### CAUTION

**DO NOT** bottom out gas valve regulator adjusting screw. This can result in unregulated manifold pressure and result in excess over-fire and heat exchanger failures.

Verify natural gas input rate by clocking meter.

1. Turn off all other gas appliances and pilots.
2. Run furnace for a minimum of 3 minutes in heating operation.
3. Measure time (in sec) for gas meter to complete 1 revolution and note reading. The 2 cubic feet dial provides a more accurate measurement of gas flow.
4. Refer to Table 14 for cubic feet of gas per hour.
5. Multiply cubic feet per hour by heating value (BTU/cu ft) to obtain input.

If clocked rate does not match the input rate from the unit nameplate, follow steps in next section to adjust the manifold pressure. Repeat steps 2 - 5 until correct input is achieved.

### CAUTION

*Be sure to relight any gas appliances that were turned off at the start of this input check.*

Table 14: Gas Rate (CU FT/HR) at Full Input

Seconds For 1 Revolution	Size of Test Dial			Seconds For 1 Revolution	Size of Test Dial		
	1 Cu Ft	2 Cu Ft	5 Cu Ft		1 Cu Ft	2 Cu Ft	5 Cu Ft
10	360	720	1800	55	65	131	327
11	327	655	1636	56	64	129	321
12	300	600	1500	57	63	126	316
13	277	555	1385	58	62	124	310
14	257	514	1286	59	61	122	305
15	240	480	1200	60	60	120	300
16	225	450	1125	62	58	116	290
17	212	424	1059	64	56	112	281
18	200	400	1000	66	54	109	273
19	189	379	947	68	53	106	265
20	180	360	900	70	51	103	257
21	171	343	857	72	50	100	250
22	164	327	818	74	48	97	243
23	157	313	783	76	47	95	237
24	150	300	750	78	46	92	231
25	144	288	720	80	45	90	225
26	138	277	692	82	44	88	220
27	133	267	667	84	43	86	214
28	129	257	643	86	42	84	209
29	124	248	621	88	41	82	205
30	120	240	600	90	40	80	200
31	116	232	581	92	39	78	196
32	113	225	563	94	38	76	192
33	109	218	545	96	38	75	188
34	106	212	529	98	37	74	184
35	103	206	514	100	36	72	180
36	100	200	500	102	35	71	178
37	97	195	486	104	35	69	173
38	95	189	474	106	34	68	170
39	92	185	462	108	33	67	167
40	90	180	450	110	33	65	164
41	88	176	439	112	32	64	161
42	86	172	429	116	31	62	155
43	84	167	419	120	30	60	150
44	82	164	409	124	29	58	145
45	80	160	400	128	28	56	141
46	78	157	391	133	27	54	135
47	76	153	383	138	26	52	130
48	75	150	375	144	25	50	125
49	73	147	367	150	24	48	120
50	72	144	360	157	23	46	115
51	71	141	355	164	22	44	110
52	69	138	346	171	21	42	105
53	68	136	340	180	20	40	100
54	67	133	333				

## ADJUSTMENT OF MANIFOLD GAS PRESSURE & INPUT RATE

Inlet and manifold gas pressure may be measured by connecting the "U" tube manometer to the gas valve with a piece of tubing. Follow the appropriate section in the instructions below. Refer to Figure 37 for a drawing of the locations of the pressure ports on the gas valve.

**Turn gas off at the ball valve or gas cock on gas supply line before the gas valve. Find the pressure ports on the gas valve marked Out P and In P.**

1. The manifold pressure must be taken at the port marked OUT P.
2. The gas line pressure must be taken at the port marked IN P.
3. Using a 3/32" (2.4 mm) Allen wrench, loosen the set screw by turning it 1 turn counter clockwise. DO NOT REMOVE THE SET SCREW FROM THE PRESSURE PORT.

### Read the inlet gas pressure

Connect the positive side of the manometer to the IN P Tap on the gas valve. Do not connect any tubing to the negative side of the manometer, as it will reference atmospheric pressure. Refer to Figure 38 for connection details.

1. Turn gas and electrical supplies on and follow the operating instructions to place the unit back in operation.

**Table 15: Inlet Gas Pressure Range**

INLET GAS PRESSURE RANGE		
	Natural Gas	Propane (LP)
Minimum	4.5" w.c. (1.12 kPa)	8.0" w.c. (1.99 kPa)
Maximum	10.5" w.c. (2.61 kPa)	13.0" w.c. (3.24 kPa).

## IMPORTANT

The inlet gas pressure operating range table specifies what the minimum and maximum gas line pressures **MUST BE** for the furnace to operate safely. The gas line pressure **MUST BE** a minimum of:

- 7" w.c. (1.74 kPa) for Natural Gas
- 11" w.c. (2.74 kPa) for Propane (LP) Gas

in order to obtain the BTU input specified on the rating plate and/or the nominal manifold pressure specified in these instructions and on the rating plate.

2. Once the correct gas inlet pressure has been established, see Table 15, turn the gas valve to OFF and turn the electrical supply switch to OFF; then remove the flexible tubing from the gas valve pressure tap and tighten the pressure tap plug using the 3/32" (2.4 mm) Allen wrench.
3. Turn the electrical and gas supplies back on, and with the burners in operation, check for gas leakage around the gas valve pressure port for leakage using an approved non-corrosive gas leak detection fluid, or other non-flammable leak detection methods.

### Read the manifold gas pressure

Connect the positive side of the manometer to the adapter previously installed in the OUT P Tap on the gas valve. Do not connect any tubing to the negative side of the manometer, as it will reference atmospheric pressure. Refer to Figure 38 for connection details.

## IMPORTANT

The cap for the pressure regulator must be removed entirely to gain access to the adjustment screw. Loosening or tightening the cap does not adjust the flow of gas.

**NOTE:** The regulated outlet pressure has been calibrated at the factory. Additional pressure adjustment should not be necessary. If adjustment is necessary, set to the following specifications. After adjustment, check for gas leakage.

1. Refer to Figure 37 for location of pressure regulator adjustment cap and adjustment screws on main gas valve.
2. Turn gas and electrical supplies on and follow the operating instructions to place the unit back in operation.
3. Adjust manifold pressure by adjusting gas valve regulator screw for the appropriate gas per the following:

**Table 16: Nominal Manifold Pressure**

NOMINAL MANIFOLD PRESSURE	
Natural Gas	3.5" w.c. (0.87 kPa)
Propane (LP) Gas	10.0" w.c. (2.488 kPa)

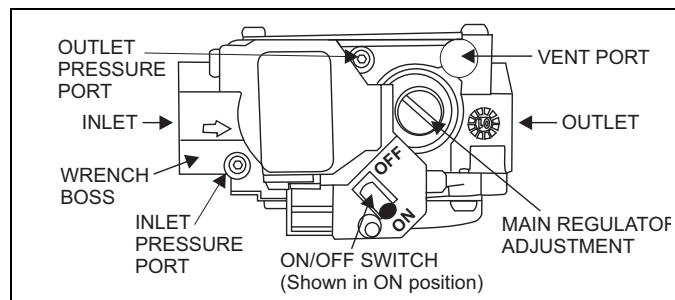
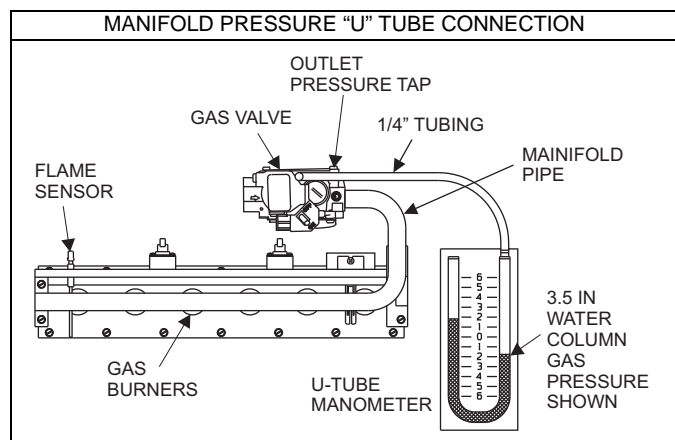

**FIGURE 37: Gas Valve**

## IMPORTANT

If gas valve regulator is turned in (clockwise), manifold pressure is increased. If screw is turned out (counterclockwise), manifold pressure will decrease.

4. After the manifold pressure has been adjusted, re-calculate the furnace input to make sure you have not exceeded the specified input on the rating plate. Refer to "CALCULATING THE FURNACE INPUT (NATURAL GAS)".
5. Once the correct BTU (kW) input has been established, turn the gas valve to OFF and turn the electrical supply switch to OFF; then remove the flexible tubing from the gas valve pressure tap and tighten the pressure tap plug using the 3/32" (2.4 mm) Allen wrench.
6. Turn the electrical and gas supplies back on, and with the burners in operation, check for gas leakage around the gas valve pressure port for leakage using an approved non-corrosive gas leak detection fluid, or other non-flammable leak detection methods.



**FIGURE 38: Reading Gas Pressure**

## ADJUSTMENT OF TEMPERATURE RISE

### **▲ DANGER**

The temperature rise, or temperature difference between the return air and the supply (heated) air from the furnace, must be within the range shown on the furnace rating plate and within the application limitations shown in Table 6.

The supply air temperature cannot exceed the “**Maximum Supply Air Temperature**” specified in these instructions and on the furnace rating plate. Under NO circumstances can the furnace be allowed to operate above the Maximum Supply Air Temperature. Operating the furnace above the Maximum Supply Air Temperature will cause premature heat exchanger failure, high levels of Carbon Monoxide, a fire hazard, personal injury, property damage, and/or death.

After about 5 minutes of operation, determine the furnace temperature rise. Take readings of both the return air and the heated air in the ducts, about six feet (1.83 m) from the furnace where they will not be affected by radiant heat. Increase the blower speed to decrease the temperature rise; decrease the blower speed to increase the rise.

### **▲ CAUTION**

Do not energize more than one motor speed at a time or damage to the motor will result.

## ADJUSTMENT OF FAN CONTROL SETTINGS

This furnace is equipped with a time-on/time-off heating fan control. The fan on delay is fixed at 30 seconds. The fan off delay has 4 settings (60, 90, 120 and 180 seconds). The fan off delay is factory set to 120 seconds. The fan-off setting must be long enough to adequately cool the furnace, but not so long that cold air is blown into the heated space. The fan-off timing may be adjusted by positioning the jumper on two of the four pins as shown in Figure 39.

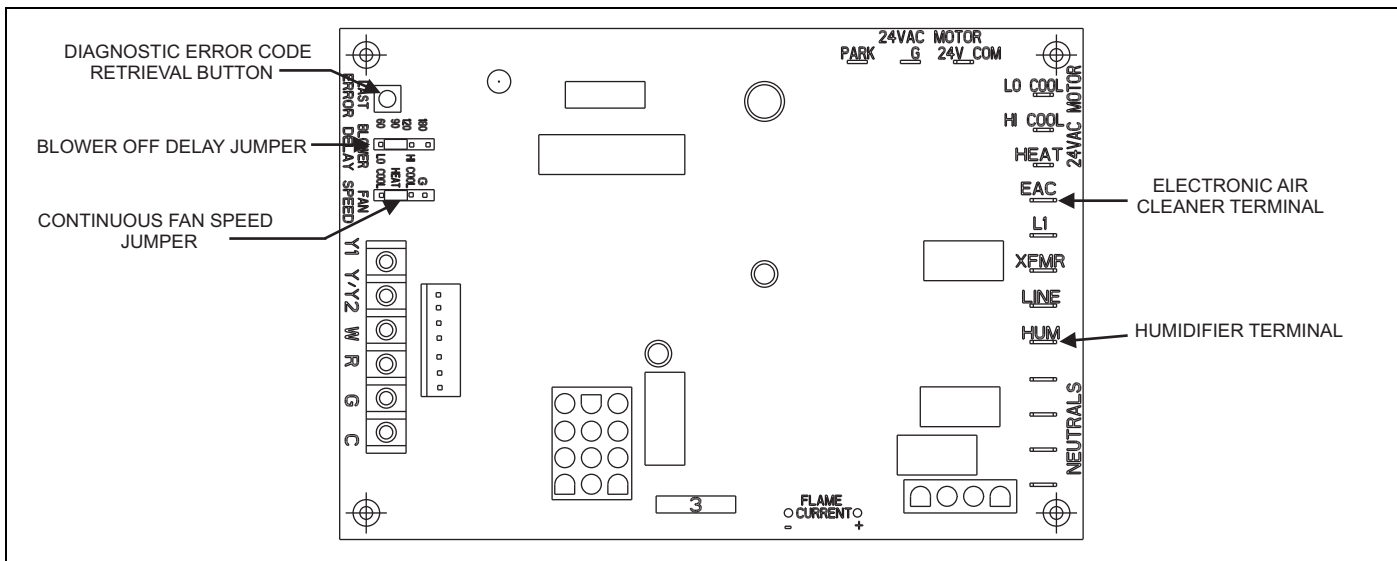

FIGURE 39: Furnace Control Board

## SECTION IX: SAFETY CONTROLS

### CONTROL CIRCUIT FUSE

A 3-amp fuse is provided on the control circuit board to protect the 24-volt transformer from overload caused by control circuit wiring errors. This is an ATO 3, automotive type fuse and is located on the control board.

### BLOWER DOOR SAFETY SWITCH

### **▲ CAUTION**

Main power to the unit must still be interrupted at the main power disconnect switch before any service or repair work is to be done to the unit. Do not rely upon the interlock switch as a main power disconnect.

Blower and burner must never be operated without the blower panel in place.

This unit is equipped with an electrical interlock switch mounted in the burner compartment. This switch interrupts all power at the unit when the panel covering the blower compartment is removed.

Electrical supply to this unit is dependent upon the panel that covers the blower compartment being in place and properly positioned.

### ROLLOUT SWITCH CONTROLS

These controls are mounted on the burner assembly. If the temperature in the area surrounding burner exceeds its set point, the gas valve is de-energized. The operation of this control indicates a malfunction in the combustion air blower, heat exchanger or a blocked vent pipe connection. Corrective action is required. These are manual reset controls that must be reset before operation can continue.

### PRESSURE SWITCHES

This furnace is supplied with two pressure switches, which monitor the flow through the combustion air/vent piping and condensate drain system. These switches de-energize the gas valve if any of the following conditions are present. Refer to "CONDENSATE PIPING AND FURNACE VENTING CONFIGURATION" for tubing connections.

1. Blockage of combustion air piping or terminals.
2. Blockage of condensate drain piping.
3. Blockage of vent piping or terminal.
4. Failure of combustion air blower motor.

## LIMIT CONTROLS

There is a high temperature limit control located on the furnace vestibule panel near the gas valve. This is an automatic reset control that provides over temperature protection due to reduced airflow. This may be caused by:

1. A dirty filter.
2. If the indoor fan motor should fail.
3. Too many supply or return registers closed or blocked off.

The control module will lockout if the limit trips 5 consecutive times. If this occurs, control will reset & try ignition again after 1 hour.

## SEQUENCE OF OPERATION

The following describes the sequence of operation of the furnace. Refer to Owners Manual for component location.

### Continuous Blower

Cooling/heating thermostats have a fan switch that has an ON and AUTO position. In the ON position the thermostat circuit is completed between terminals R and G. The motor will operate continuously on the speed tap wire that is connected to the HI COOL cooling terminal on the control board. To obtain a constant air circulation at lower flow rate, change the high-speed wire to either the medium speed wire or the low speed wire.

### Intermittent Blower - Cooling

Cooling/heating thermostats have a fan switch that has an ON and AUTO position. In the AUTO position the thermostat circuit is completed between terminals R and G when there is a call for cooling. The motor will operate on the speed tap wire that is connected to the HI COOL cooling terminal on the control board. The fan off setting is fixed at 60 seconds to improve cooling efficiency.

### Heating Cycle

When the thermostat switch is set on HEAT and the fan is set on AUTO, and there is a call for heat, a circuit is completed between terminals R and W of the thermostat. When the proper amount of combustion air is being provided, the pressure switch will close, the ignition control provides a 17-second ignitor warm-up period, the gas valve then opens, the gas starts to flow, ignition occurs and the flame sensor begins its sensing function. The blower motor will energize 30 seconds after the gas valve opens, if a flame is detected. Normal furnace operation will continue until the thermostat circuit between R and W is opened, which causes the ignition system and gas valve to de-energize and the burner flames to be extinguished. The vent motor will operate for 15 seconds and the blower motor will operate for the amount of time set by the fan-off delay jumper located on the control board. See Figure 39. The heating cycle is now complete, and ready for the start of the next heating cycle.

If the flame is not detected within 7 seconds of the gas valve opening, the gas valve is shut off and a retry operation begins. Also, if the flame is lost for 2 seconds during the 10-second stabilization period, the gas valve is shut off and a retry operation begins. During a retry operation, the vent motor starts a 15 second inter-purge and the ignitor warm-up time is extended to 27 seconds. If the flame is established for more than 10 seconds after ignition during a retry, the control will clear the ignition attempt (retry) counter. If three retries occur during a call for heat, the furnace will shut down for one hour. If at the end of the one hour shut down there is a call for heat, the furnace will initiate a normal start cycle. If the problem has not been corrected the furnace will again lockout after three retries.

A momentary loss of gas supply, flame blowout, or a faulty flame probe circuit will result in a disruption in the flame and be sensed within 1.0 seconds. The gas valve will de-energize and the control will begin a recycle operation. A normal ignition sequence will begin after a 15 second inter-purge. If during the five recycles the gas supply does not return, or the fault condition is not corrected the ignition control will lockout for 60 minutes.

During burner operation, a momentary loss of power for 50 milliseconds or longer will de-energize the gas valve. When the power is restored, the gas valve will remain de-energized and the ignition sequence will immediately restart.

## Hot Surface Ignition System

### **WARNING**

#### **HOT SURFACE IGNITION SYSTEM**

**Do not attempt to light this furnace by hand (with a match or any other means). There may be a potential shock hazard from the components of the hot surface ignition system. The furnace can only be lit automatically by its hot surface ignition system.**

## TROUBLESHOOTING

The following visual checks should be made before troubleshooting:

1. Check to see that the power to the furnace and the ignition control module is ON.
2. The manual shut-off valves in the gas line to the furnace must be open.
3. Make sure all wiring connections are secure.
4. Review the sequence of operation. Start the system by setting the thermostat above the room temperature. Observe the system's response. Then use the troubleshooting section in this manual to check the system's operation.

### **WARNING**

**Never bypass any safety control to allow furnace operation. To do so will allow furnace to operate under potentially hazardous conditions.**

**Do not try to repair controls. Replace defective controls with UPG Source 1 Parts.**

**Never adjust pressure switch to allow furnace operation.**

## FURNACE CONTROL DIAGNOSTICS

The furnace has built-in, self-diagnostic capability. If a system problem occurs, a blinking LED can flash red, green or amber to indicate various conditions.

The control continuously monitors its own operation and the operation of the system. If a failure occurs, the LED will indicate the failure code. If the failure is internal to the control, the light will stay on continuously. In this case, the entire control should be replaced, as the control is not field repairable.

Flash sequence codes 1 through 11 are as follows: LED will turn ON for 1/4 second and OFF for 1/4 second. This pattern will be repeated the number of times equal to the code. For example, six ON flashes equals a number 6 fault code. All flash code sequences are broken by a 2 second OFF period.

**SLOW GREEN FLASH:** Normal operation.

**SLOW AMBER FLASH:** Normal operation with call for heat.

**RAPID RED FLASH:** Twinning error, incorrect 24V phasing. Check twinning wiring.

**RAPID AMBER FLASH:** Flame sense current is below 1.5 microamps. Check and clean flame sensor. Check for proper gas flow. Verify that current is greater than 1.5 microamps at flame current test pad.

**4 AMBER FLASHES:** The control is receiving a "Y" signal from the thermostat without a "G" signal, indicating improper thermostat wiring.

**1 RED FLASH:** This indicates that flame was sensed when there was not a call for heat. The control will turn on both the inducer motor and supply air blower. A gas valve that leaks or is slow closing would typically cause this fault.

**2 RED FLASHES:** This indicates that the normally open pressure switch contacts are stuck in the closed position. The control confirms these contacts are open at the beginning of each heat cycle. This would indicate a faulty pressure switch or miswiring.

**3 RED FLASHES:** This indicates the normally open pressure switch contact did not close after the inducer was energized. This could be caused by a number of problems: faulty inducer, blocked vent pipe, broken pressure switch hose or faulty pressure switch.

**4 RED FLASHES:** This indicates that the main limit switch has opened its normally closed contacts. The control will operate the supply air blower and inducer. This condition may be caused by: dirty filter, improperly sized duct system, incorrect blower speed setting, incorrect firing rate or faulty blower motor. Also, this fault code could be caused by a blown fuse located on the circuit board.

**5 RED FLASHES:** This fault is indicated if the normally closed contacts in the rollout switch opens. The rollout control is manually reset. If it has opened, check for proper combustion air, proper inducer operation, and primary heat exchanger failure or burner problem. Be sure to reset the switch and cycle power (24 VAC) to the control after correcting the failure condition. Also, this fault code could be caused by a blown fuse located on the circuit board.

**6 RED FLASHES:** This indicates that after the unit was operating, the pressure switch opened 4 times during the call for heat. If the main blower is in a "Delay on" mode, it will complete it, and any subsequent delay off period. The furnace will lock out for one hour and then restart.

**7 RED FLASHES:** This fault code indicates that the flame could not be established. This no-light condition occurred 3 times (2 retries) during the call for heat before locking out. Low gas pressure, faulty gas valve, dirty or faulty flame sensor, faulty hot surface ignitor or burner problem may cause this. The furnace will lock out for one hour and then restart.

**8 RED FLASHES:** This fault is indicated if the flame is lost 5 times (4 recycles) during the heating cycle. This could be caused by low gas pressure, dirty or faulty flame sensor or faulty gas valve. The furnace will lock out for one hour and then restart.

**9 RED FLASHES:** Indicates reversed line voltage polarity or grounding problem. Both heating and cooling operations will be affected. Check polarity at furnace and branch. Check furnace grounding. Check that flame probe is not shorted to chassis.

**10 RED FLASHES:** Flame sensed with no call for heat. Check gas valve and gas valve wiring.

**11 RED FLASHES:** This indicates that a primary or auxiliary limit switch has opened its normally-closed contacts and has remained open for more than five minutes. This condition is usually caused by a failed blower motor or blower wheel. Cycle power (24 VAC) to the control to reset the hard lockout condition after correcting the failure condition.

**12 RED FLASHES:** This code indicates an open igniter circuit, which could be a disconnected or loose wire or a cracked or broken igniter.

**STEADY ON RED:** Control failure. Replace control board.

**60-MINUTE AUTOMATIC RESET FROM LOCKOUT:** This control includes a "watchdog" type circuit that will reset from a lockout condition after 60 minutes. Operational faults 6,7,8 will be reset. This provides protection to an unoccupied structure if a temporary condition exists causing a furnace malfunction. An example would be a low incoming gas supply pressure preventing unit operation. When the gas pressure is restored, at some point the "watchdog" would restart the unit and provide heat for the house.

**NOTE:** If a flame is detected the control flashes the LED for 1/8 of a second and then enters a flame stabilization period.

**IGNITION CONTROL FLAME SENSE LEVELS**  
 Normal flame sense current is approximately  
 3.7 microamps DC (µa)  
 Low flame signal warning starts at 1.5 microamps.  
 Low flame signal control lockout point is  
 0.1 microamps DC (µa)

**DIAGNOSTIC FAULT CODE STORAGE AND RETRIEVAL**

The control in this furnace is equipped with memory that will store up to five error codes to allow a service technician to diagnose problems more easily. This memory will be retained even if power to the furnace is lost. **This feature should only be used by a qualified service technician.**

If more than five error codes have occurred since the last reset, only the five most recent will be retained. The furnace control board has a button, labeled LAST ERROR that is used to retrieve error codes. This function will only work if there are no active thermostat signals. So any call for heating, cooling or continuous fan must be terminated before attempting to retrieve error codes.

To retrieve the error codes, push the LAST ERROR button. The LED on the control will then flash the error codes that are in memory, starting with the most recent. There will be a two-second pause between each flash code. After the error codes have all been displayed, the LED will resume the normal slow green flash after a five second pause. To repeat the series of error codes, push the button again.

If there are no error codes in memory, the LED will flash two green flashes. To clear the memory, push the LAST ERROR button and hold it for more than five seconds. The LED will flash three green flashes when the memory has been cleared, then will resume the normal slow green flash after a five-second pause.

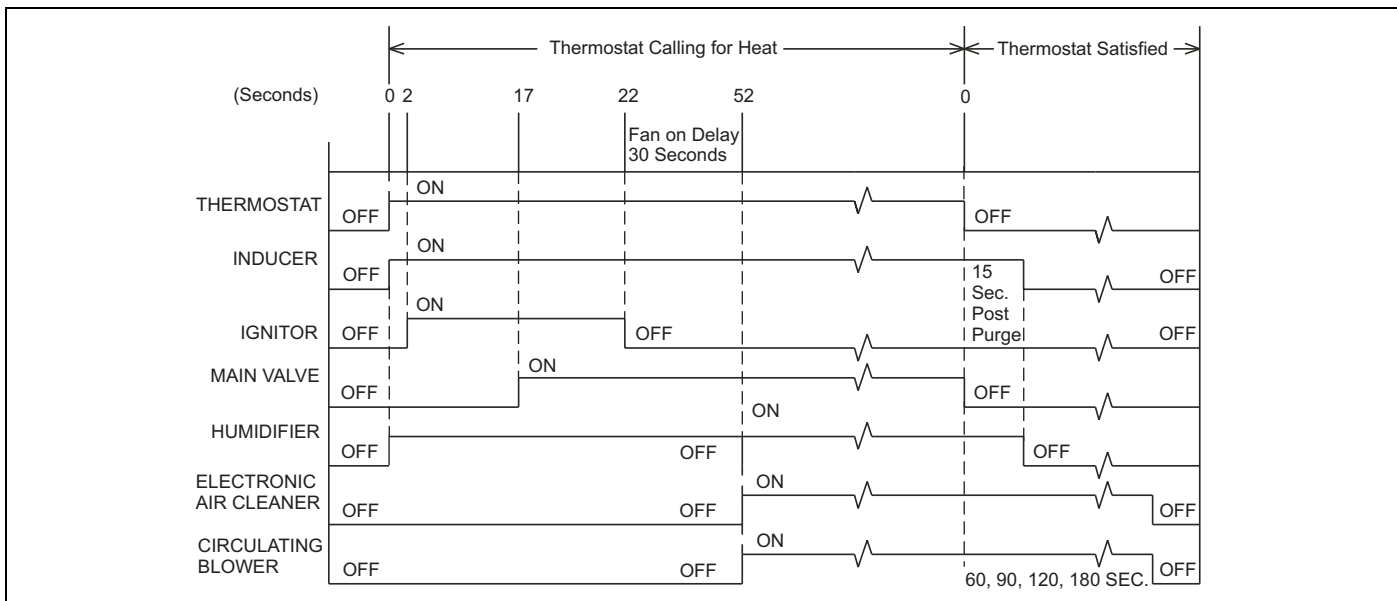

**FIGURE 40:** Furnace Control Event Schedule

## SECTION X: REPLACEMENT PARTS LIST

DESCRIPTION
<b>MOTOR</b>
BLOWER, COMBUSTION
MOTOR, DIRECT DRIVE BLOWER
<b>ELECTRICAL</b>
CONTROL, FURNACE
CONTROL, TEMPERATURE
IGNITER
SENSOR, FLAME
SWITCH, DOOR
SWITCH, LIMIT
SWITCHES, PRESSURE
TRANSFORMER
VALVE, GAS
<b>AIR MOVING</b>
HOUSING, BLOWER
WHEEL, BLOWER
<b>FABRICATED PARTS</b>
BRACKET, BLOWER TRACK (2 req'd)
BRACKET, IGNITER
BURNER, MAIN GAS
HEAT EXCHANGER ASS'Y
MANIFOLD, GAS
PANEL, BLOCKOFF
PAN, BOTTOM
PANEL, DOOR (2 req'd)

DESCRIPTION
<b>FABRICATED PARTS Continued</b>
PANEL, TOP
RAIL, BLOWER (2 req'd)
RESTRICTOR, COMBUSTION BLOWER
SHELF, BLOWER
<b>MISCELLANEOUS</b>
BAG, PARTS
BRACKET, DOOR
DIAGRAM, WIRING
FERRULE (3 req'd)
GASKET, FOAM (Door) (1.5 ft req'd)
GROMMET (3 req'd)
HARNESS, WIRING
HOSE, CONDENSATE
HOSE, RAIN GUTTER
KNOB, QUARTER TURN (4 req'd)
MOTOR MOUNT
ORIFICE, BURNER (Natural #45)
PAN, CONDENSATE
PLUG, SEAL, 7/8"
PLUG, SEAL, 2-3/8"
PLUG, VENT PIPE
SIGHT GLASS, OVAL (2 req'd)
TUBING, SILICON

---

**REPLACEMENT PART CONTACT INFORMATION**

This is a generic parts list. To request a complete parts list, refer to the contact information below:

- Visit our website at [www.source1parts.com](http://www.source1parts.com) for the following information:
  1. Search for a part or browse the catalog.
  2. Find a dealer or distributor.
  3. Customer Service contact information.
    - a. Click on the "Brand Links" button
    - b. Click on the "Customer Service" button
- You can contact us by mail. Just send a written request to:

**Johnson Controls Unitary Products  
Consumer Relations  
5005 York Drive  
Norman, OK 73069**

---

# SECTION XI: WIRING DIAGRAM

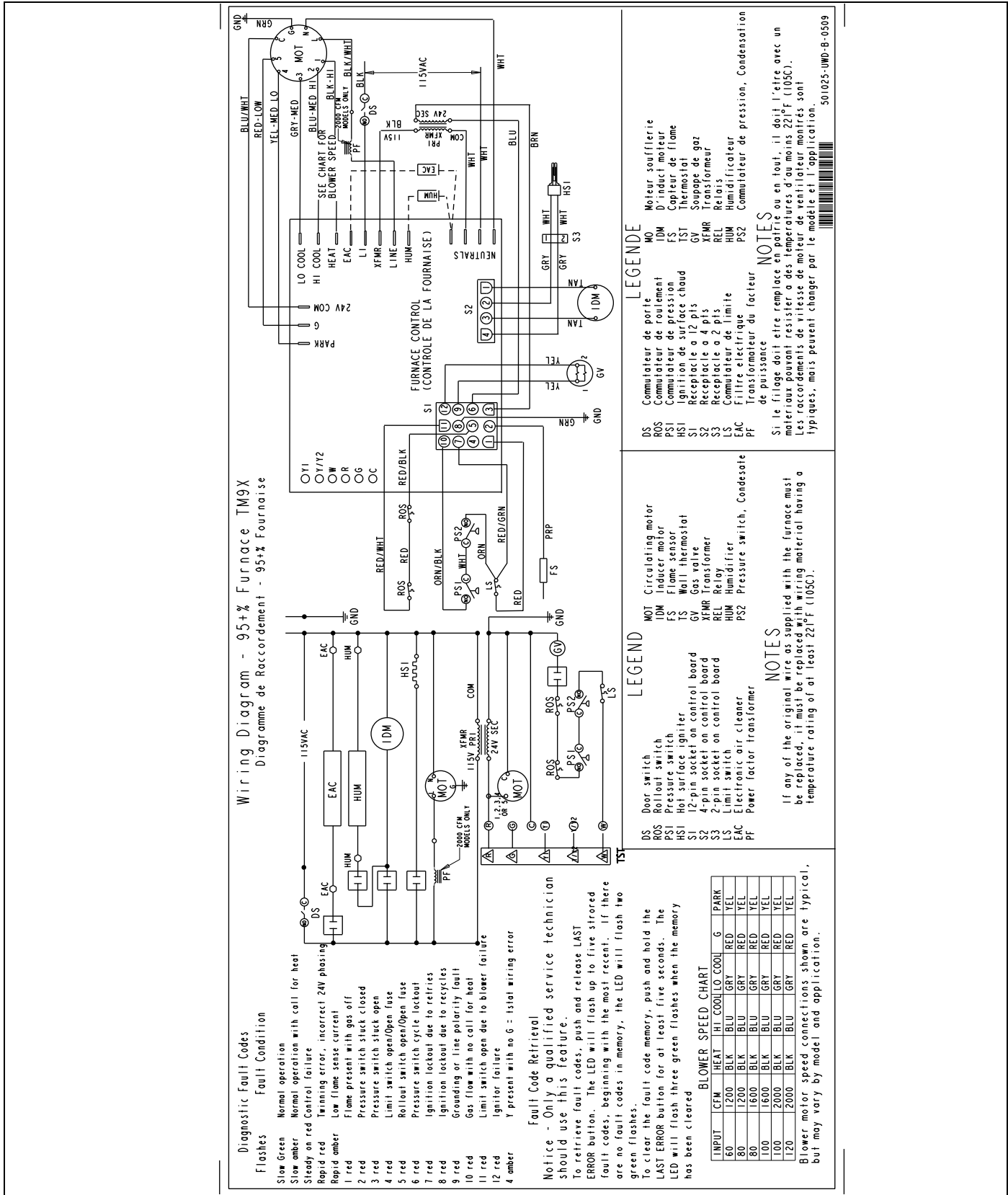

FIGURE 41: Wiring Diagram

Subject to change without notice. Published in U.S.A.  
 Copyright © 2009 by Johnson Controls, Inc. All rights reserved.

501028-UIM-B-0509  
 Supersedes: 501028-UIM-A-0209